

Introduction to Beamforming and Source Separation

Stephan Weiss

Centre for Signal & Image Processing
Department of Electronic & Electrical Engineering
University of Strathclyde, Glasgow, Scotland, UK

UDRC-EURASIP Summer School, Edinburgh, 30 June 2022

This work was supported by the Engineering and Physical Sciences Research Council (EPSRC) Grant number EP/S000631/1 and the MOD University Defence Research Collaboration in Signal Processing.

1 Beamforming



Contents:

1. Introduction	1
2. Spatial Sampling	2
3. Steering Vector	3
4. Data Independent Beamformer Design	4
5. Statistically Optimum Beamformer Design	8
6. Beamforming and MIMO	9
7. Broadband beamforming	10
8. Summary	11

1.1 Intuitive Beamforming

- ▶ A farfield wavefront arrives at a sensor array:

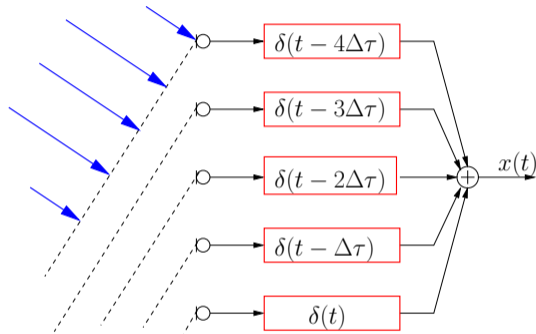

- ▶ due to the direction of arrival (DOA) and finite propagation speed, the wavefront will arrive at different sensors with a delay $\Delta\tau$;
- ▶ with appropriate **processing (beamforming)**, the sensor signals can be aligned to create constructive interference at the output $x(t)$.

1.2 Spatial Sampling

- ▶ For unambiguous **spatial sampling**, we need to take **at least two samples per wavelength** of the highest frequency component in the array signals;
- ▶ analogy from **temporal sampling (Nyquist)**: take at **least two samples per period** (relating to the highest frequency component);
- ▶ Wavelength λ and frequency f are related by the propagation speed c in the medium:
 $\lambda = \frac{c}{f}$;

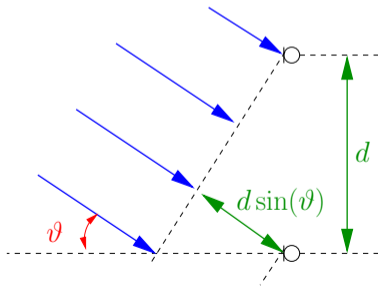

- ▶ maximum sensor distance

$$d = \frac{\lambda_{\max}}{2} = \frac{c}{2f_{\max}}$$

- ▶ time delay between sensors

$$\Delta\tau = \frac{d \sin(\vartheta)}{c} = \frac{\sin(\vartheta)}{2f_{\max}}$$

Spatial and Temporal Sampling

- ▶ Consider the array signals $x_0(t)$ and $x_1(t)$ due to a source $e^{j(\omega t + \varphi_0)}$:

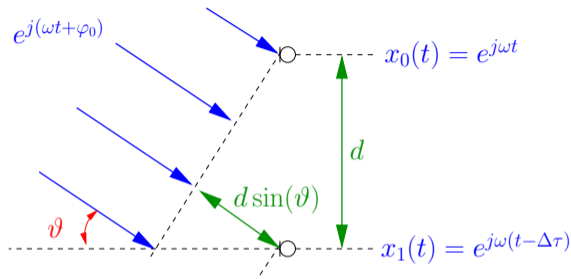

- ▶ sampling with $t = nT_s$ leads to

$$x_0[n] = e^{j\omega n T_s} \quad \text{and} \quad x_1[n] = e^{j\omega(nT_s - \Delta\tau)}$$

- ▶ with $f_{\max} = \frac{f_s}{2} = \frac{1}{2T_s}$ and normalised angular frequency $\Omega = \omega T_s$,

$$x_0[n] = e^{j\Omega n} \quad \text{and} \quad x_1[n] = e^{j\Omega n} \cdot e^{-j\Omega \sin(\vartheta)}$$

1.3 Steering Vector

- ▶ A narrowband source with norm. angular frequency Ω illuminates an M -element linear array of equispaced sensors:

$$\mathbf{x}[n] = \begin{bmatrix} x_0[n] \\ x_1[n] \\ \vdots \\ x_{M-1}[n] \end{bmatrix} = e^{j\Omega n} \cdot \begin{bmatrix} 1 \\ e^{-j\Omega \sin(\vartheta)} \\ \vdots \\ e^{-j(M-1)\Omega \sin(\vartheta)} \end{bmatrix} = e^{j\Omega n} \cdot \mathbf{s}_{\Omega, \vartheta}$$

- ▶ the vector $\mathbf{s}_{\Omega, \vartheta}$ characterises the phase shifts of waveform with frequency Ω and DOA ϑ measured at the array sensors;
- ▶ since a narrowband signal $e^{j\Omega n}$ only causes phase shifts rather than delays, constructive interference can be accomplished by a set of complex multipliers rather than processors $\delta(t - m\Delta\tau)$, $m = 0, 1, \dots (M - 1)$;
- ▶ beamforming problem: how to select the set of complex coefficients?

1.4 Data Independent Beamformer

- Find a set of complex multipliers w_m , $m = 0, 1, \dots, (M - 1)$:

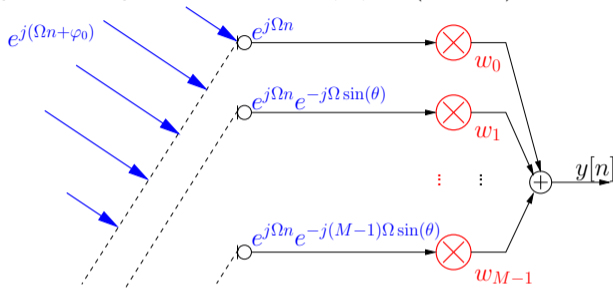

- to steer the array characteristic towards this source, the output

$$y[n] = [w_0 \ w_1 \ \dots \ w_{M-1}] e^{j\Omega n} \begin{bmatrix} 1 \\ e^{-j\Omega \sin(\vartheta)} \\ \vdots \\ e^{-j(M-1)\Omega \sin(\vartheta)} \end{bmatrix} = e^{j\Omega n} \mathbf{w}^H \mathbf{s}_{\Omega, \vartheta}$$

should fulfill $y[n] = e^{j\Omega n}$, leading to $\mathbf{w}^H \mathbf{s}_{\Omega, \vartheta} = 1$.

Coefficient Vector

- ▶ For later convenience and compatibility, the Hermitian transpose operator $\{\cdot\}^H$ is used to denote the coefficient vector

$$\mathbf{w}^H = [w_0 \ w_1 \ \dots \ w_{M-1}]$$

- ▶ as a result, the vector \mathbf{w} hold the **complex conjugates** of the coefficients,

$$\mathbf{w} = \begin{bmatrix} w_0^* \\ w_1^* \\ \vdots \\ w_{M-1}^* \end{bmatrix}$$

- ▶ to access the actual unconjugated coefficients, the beamforming vector \mathbf{w}^* has to be considered
- ▶ note that

$$\mathbf{w}^H \mathbf{s}_{\Omega, \vartheta} = 1 \quad \longrightarrow \quad \mathbf{s}_{\Omega, \vartheta}^H \mathbf{w} = 1$$

Narrowband Beamforming — Single Source

- ▶ The expression $\mathbf{s}_{\Omega,\vartheta}^H \mathbf{w} = 1$ forms a system with one single equation and M unknowns

$$\boxed{\mathbf{s}_{\Omega,\vartheta}^H} \boxed{\mathbf{w}} = \boxed{1}$$

- ▶ general solution to an underdetermined system $\mathbf{A}\mathbf{x} = \mathbf{b}$ is the right pseudo-inverse \mathbf{A}^\dagger ,

$$\mathbf{x} = \mathbf{A}^\dagger \mathbf{b} = \mathbf{A}^H (\mathbf{A}\mathbf{A}^H)^{-1} \mathbf{b}$$

- ▶ here:

$$\mathbf{w} = (\mathbf{s}_{\Omega,\vartheta}^H)^\dagger \cdot 1 = \mathbf{s}_{\Omega,\vartheta} \cdot (\mathbf{s}_{\Omega,\vartheta}^H \mathbf{s}_{\Omega,\vartheta})^{-1} \cdot 1 = \frac{\mathbf{s}_{\Omega,\vartheta}}{\|\mathbf{s}_{\Omega,\vartheta}\|_2^2} = \frac{1}{M} \mathbf{s}_{\Omega,\vartheta}$$

- ▶ the complex conjugation for \mathbf{w}^* inverts and therefore compensates the phase of the steering vector, which could have been foreseen
- ▶ the formulation via the pseudo-inverse will be powerful for more complicated cases.

Narrowband Beamformer Example

- ▶ Source parameters: $\Omega = \frac{\pi}{2}$ and $\vartheta = 30^\circ$; array parameter: $M = 5$;
- ▶ steering vector (with $\Omega \sin(\vartheta) = \frac{1}{4}\pi$):

$$\mathbf{s}_{\Omega, \vartheta}^T = [1 \ e^{-j\frac{1}{4}\pi} \ \dots \ e^{-j\frac{4}{4}\pi}]$$

- ▶ coefficient vector is given by $\mathbf{w} = (\mathbf{s}_{\Omega, \vartheta}^H)^{\dagger}$;
- ▶ numerical solution in Matlab;

```
Omega=1/4; theta = pi/6; M=5;
s = exp(-sqrt(-1)*Omega*sin(theta)*(0:(M-1)'));
w = pinv(s');
```
- ▶ `angle([s conj(w)])/pi` yields:

-0.00000	0.00000
-0.25000	0.25000
-0.50000	0.50000
-0.75000	0.75000
-1.00000	1.00000

Beam Pattern I

- ▶ The beamformer has a unit gain towards a source with frequency Ω and DoA θ ; what is its gain response towards other angles of arrival?
- ▶ the beam pattern measures the response of a beamformer by sweeping the angle ψ of a source with frequency Ω

$$g(\Omega, \psi) = \mathbf{w}^H \mathbf{s}_{\Omega, \psi}$$

- ▶ beam pattern for the previous example:

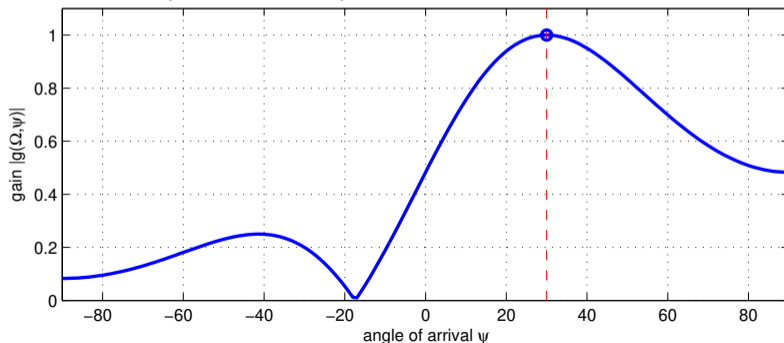

Beam Pattern II

- ▶ Below are a number of beam patterns for the case $\Omega = \frac{\pi}{2}$ and $\vartheta = 30^\circ$ for variable M ;

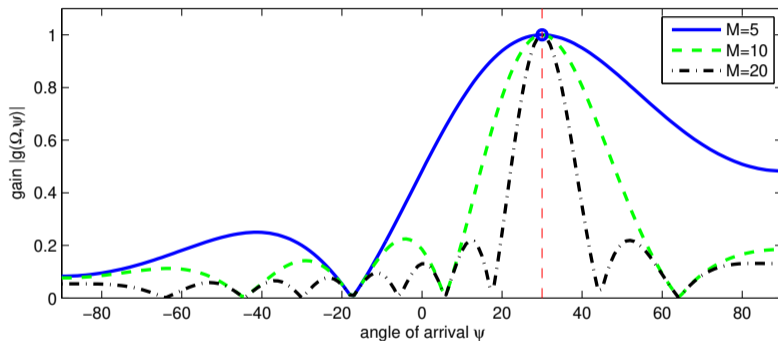

- ▶ increasing the sensor number M narrows the main beam, and increases the number of spatial zeros;
- ▶ analogous characteristic in the time domain: increased temporal support leads to higher frequency resolution.

Interference

- ▶ Many scenarios contain a source of interest and a number of interferers:

signal of interest:

$$\{\Omega_0, \vartheta_0\}$$

two interferers:

$$\{\Omega_1, \vartheta_1\}, \{\Omega_2, \vartheta_2\}$$

- ▶ we would like to control the beampattern to place spatial nulls in the directions of the interfering sources;
- ▶ Problem formulation and solution :

$$\begin{bmatrix} \mathbf{s}_{\Omega_0, \vartheta_0}^H \\ \mathbf{s}_{\Omega_1, \vartheta_1}^H \\ \mathbf{s}_{\Omega_2, \vartheta_2}^H \end{bmatrix} \mathbf{w} = \begin{bmatrix} 1 \\ 0 \\ 0 \end{bmatrix} \quad \longrightarrow \quad \mathbf{w} = \begin{bmatrix} \mathbf{s}_{\Omega_0, \vartheta_0}^H \\ \mathbf{s}_{\Omega_1, \vartheta_1}^H \\ \mathbf{s}_{\Omega_2, \vartheta_2}^H \end{bmatrix}^\dagger \begin{bmatrix} 1 \\ 0 \\ 0 \end{bmatrix}$$

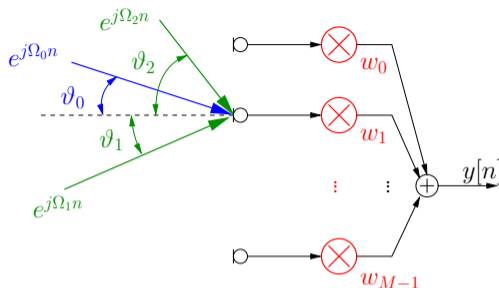

Narrowband BF Example — Multiple Sources

- ▶ The signal of interest illuminates an $M = 5$ element array at a frequency $\Omega_0 = \frac{\pi}{2}$ with a DoA $\vartheta_0 = 30^\circ$
- ▶ two interferers at $\Omega_1 = \Omega_2 = \Omega_0$ are present with DoA $\vartheta_1 = -45^\circ$ and $\vartheta_2 = 60^\circ$
- ▶ results via right pseudo-inverse of steering vectors

$\angle \mathbf{s}_{\Omega_0, \vartheta_0}$	$\angle \mathbf{s}_{\Omega_1, \vartheta_1}$	$\angle \mathbf{s}_{\Omega_2, \vartheta_2}$	$\angle \mathbf{w}^*$	$ \mathbf{w} $
0.00	0.00	0.00	-42.81	0.3172
45.00	63.64	-77.94	-105.01	0.3004
90.00	127.28	-155.89	-90.00	0.2343
135.00	-169.08	126.17	-74.99	0.3004
180.00	-105.44	48.23	-137.19	0.3172

- ▶ the angle of \mathbf{w} is no longer intuitive; also note that the coefficients in \mathbf{w} no longer have the same modulus
- ▶ amongst a manifold of solutions, the right pseudo-inverse provides the minimum norm solution.

Multiple Source Example — Beampattern

- ▶ Beam pattern one source of interest and two interferers:

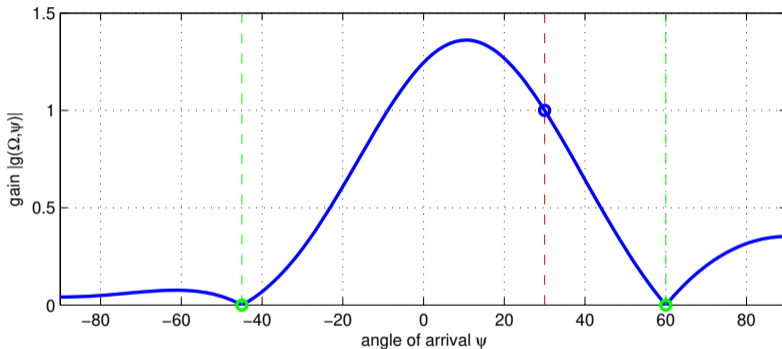

- ▶ the pseudo-inverse is the minimum norm solution, keeping the general gain response as low as possible;
- ▶ the minimum norm property protects against spatially white noise.

Beamforming Example — Variable Interferer I

- ▶ $M = 5$ sensors, source of interest towards $\theta_0 = 30^\circ$, interferer variable:

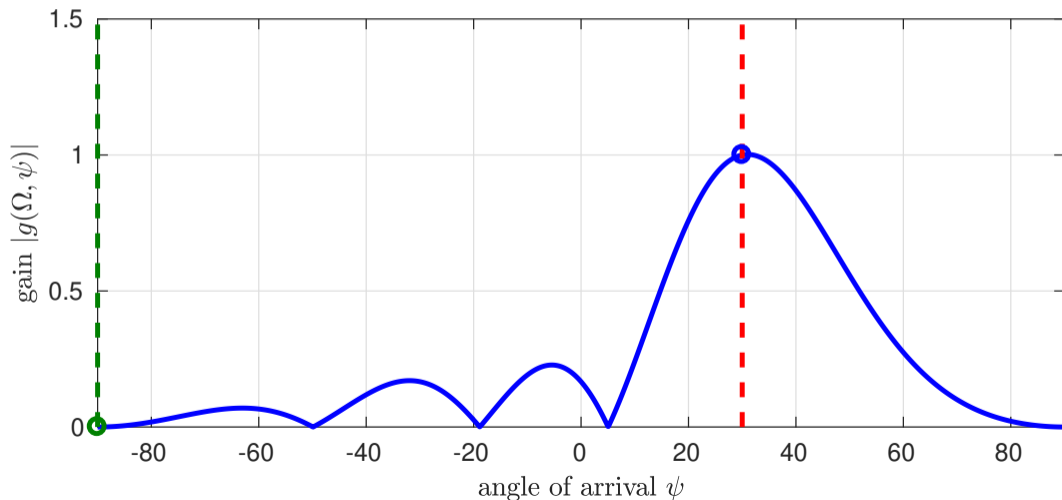

Beamforming Example — Variable Interferer I

- ▶ $M = 5$ sensors, source of interest towards $\theta_0 = 30^\circ$, interferer variable:

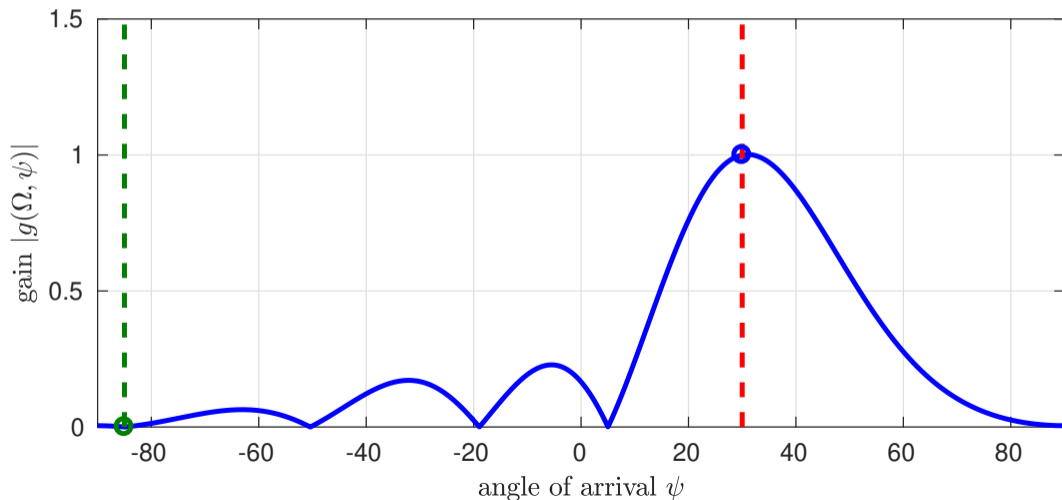

Beamforming Example — Variable Interferer I

- ▶ $M = 5$ sensors, source of interest towards $\theta_0 = 30^\circ$, interferer variable:

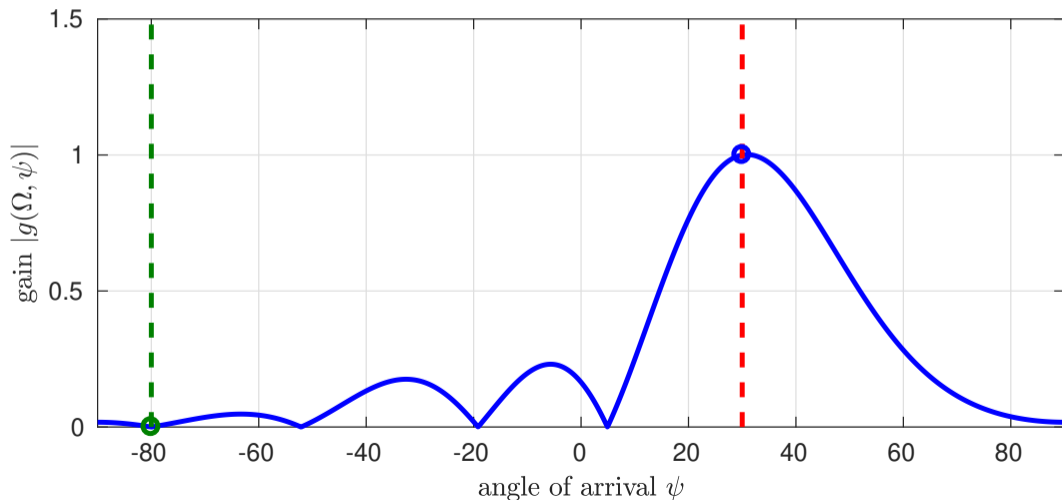

Beamforming Example — Variable Interferer I

- ▶ $M = 5$ sensors, source of interest towards $\theta_0 = 30^\circ$, interferer variable:

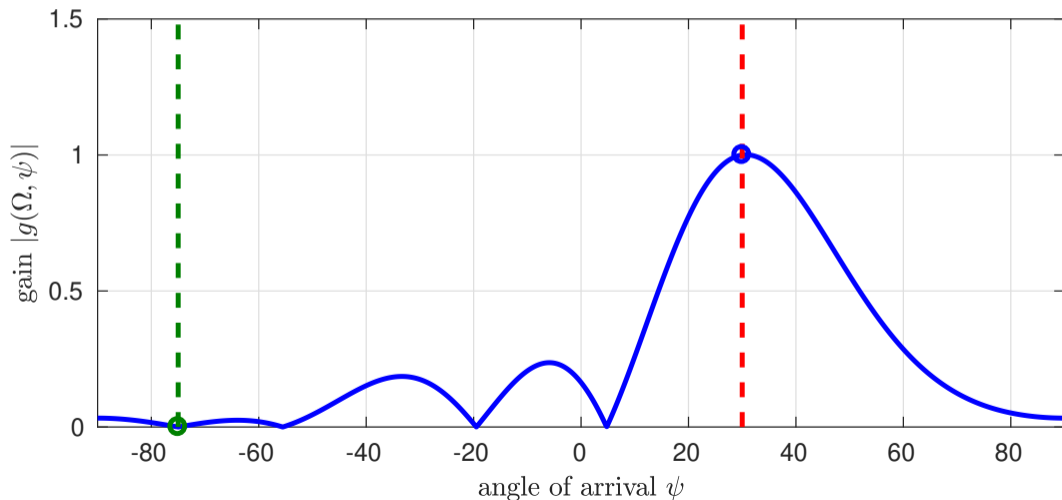

Beamforming Example — Variable Interferer I

- ▶ $M = 5$ sensors, source of interest towards $\theta_0 = 30^\circ$, interferer variable:

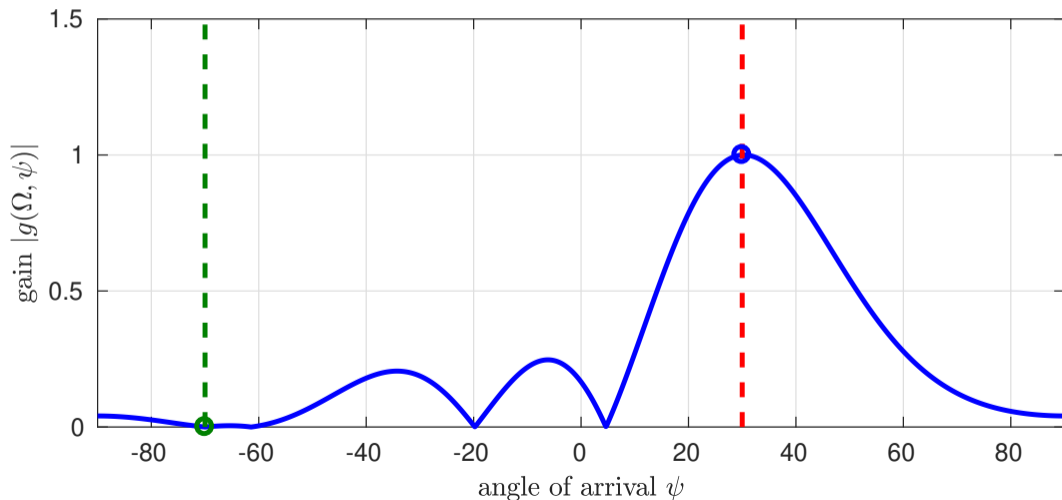

Beamforming Example — Variable Interferer I

- ▶ $M = 5$ sensors, source of interest towards $\theta_0 = 30^\circ$, interferer variable:

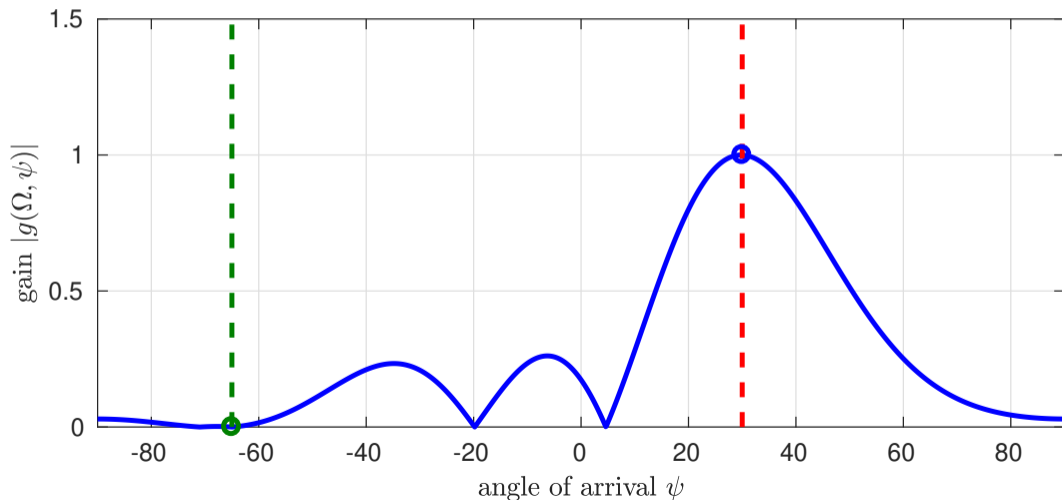

Beamforming Example — Variable Interferer I

- ▶ $M = 5$ sensors, source of interest towards $\theta_0 = 30^\circ$, interferer variable:

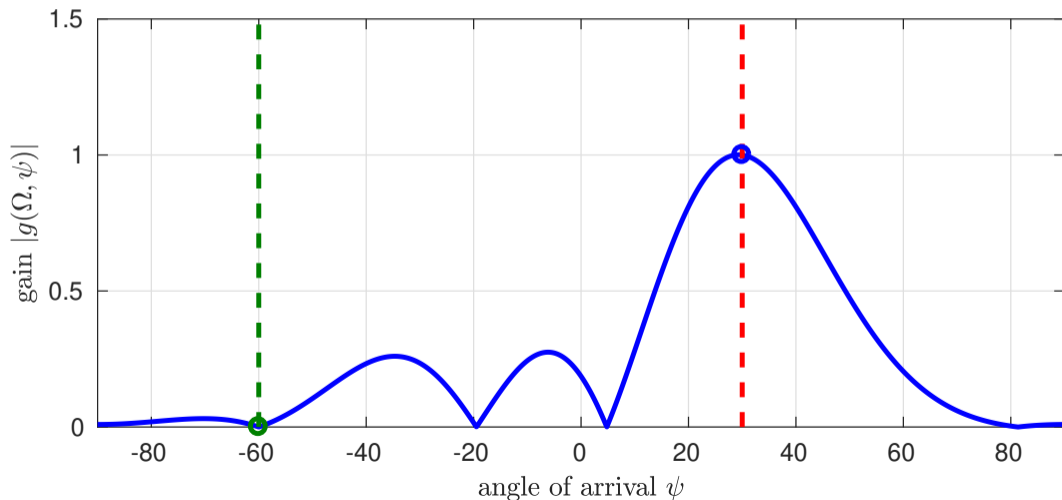

Beamforming Example — Variable Interferer I

- ▶ $M = 5$ sensors, source of interest towards $\theta_0 = 30^\circ$, interferer variable:

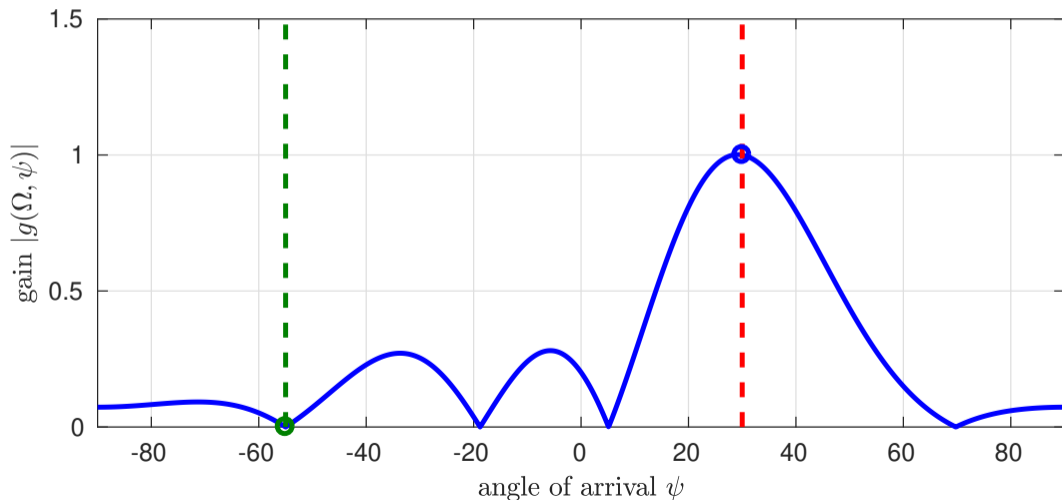

Beamforming Example — Variable Interferer I

- ▶ $M = 5$ sensors, source of interest towards $\theta_0 = 30^\circ$, interferer variable:

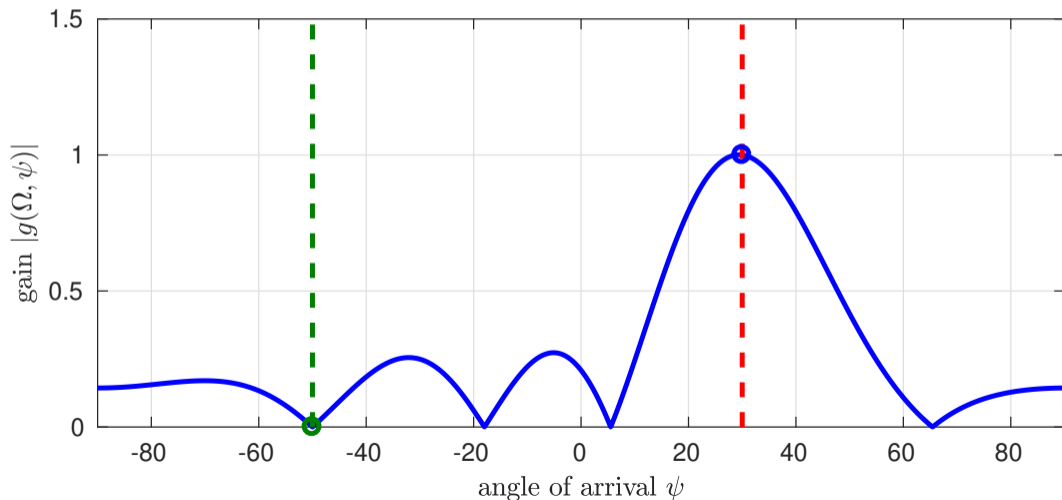

Beamforming Example — Variable Interferer I

- ▶ $M = 5$ sensors, source of interest towards $\theta_0 = 30^\circ$, interferer variable:

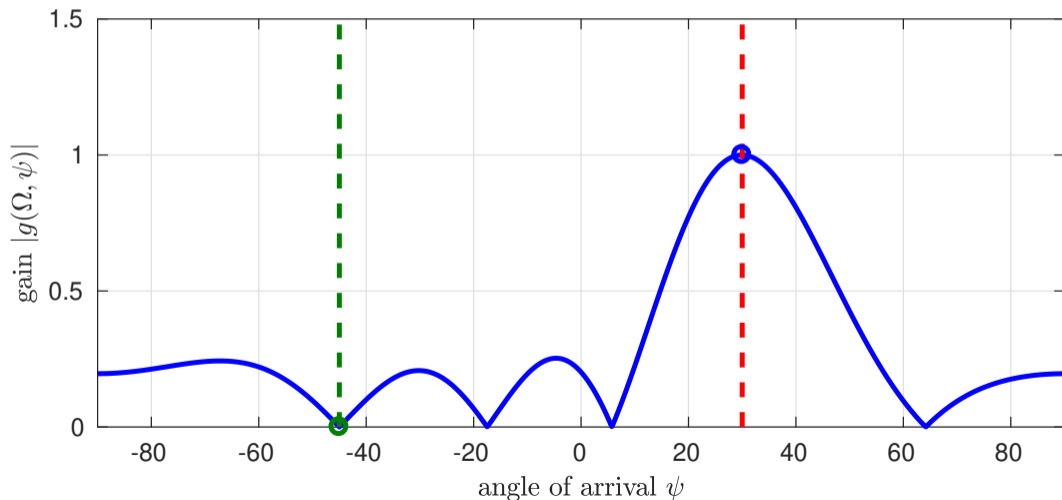

Beamforming Example — Variable Interferer I

- ▶ $M = 5$ sensors, source of interest towards $\theta_0 = 30^\circ$, interferer variable:

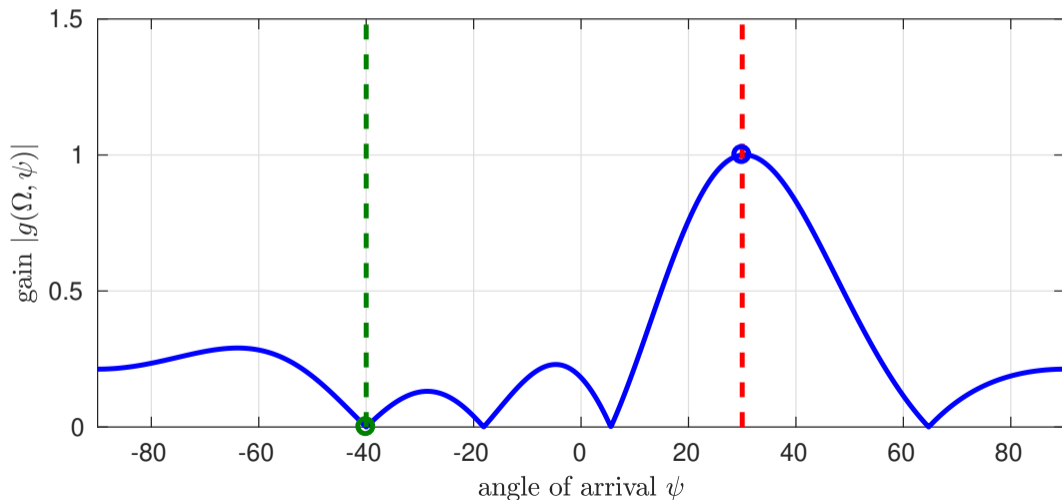

Beamforming Example — Variable Interferer I

- ▶ $M = 5$ sensors, source of interest towards $\theta_0 = 30^\circ$, interferer variable:

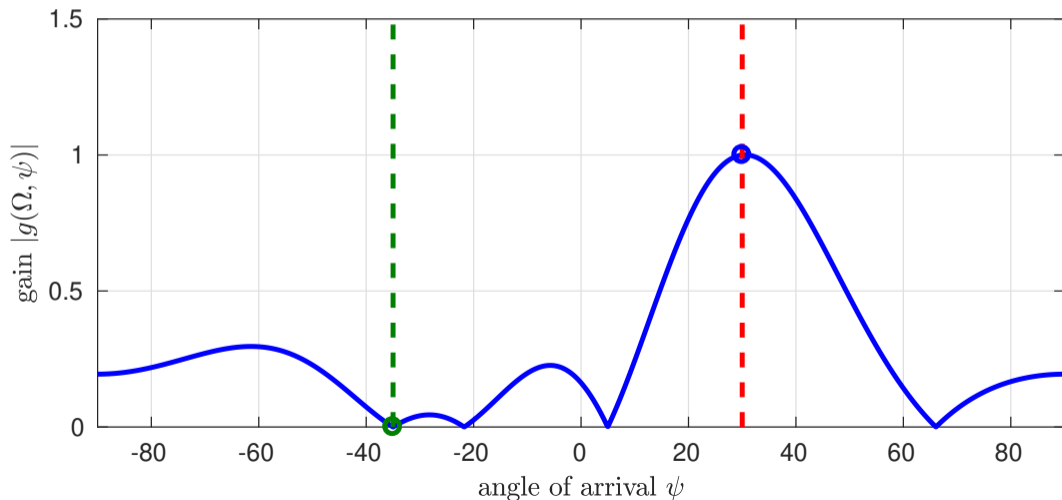

Beamforming Example — Variable Interferer I

- ▶ $M = 5$ sensors, source of interest towards $\theta_0 = 30^\circ$, interferer variable:

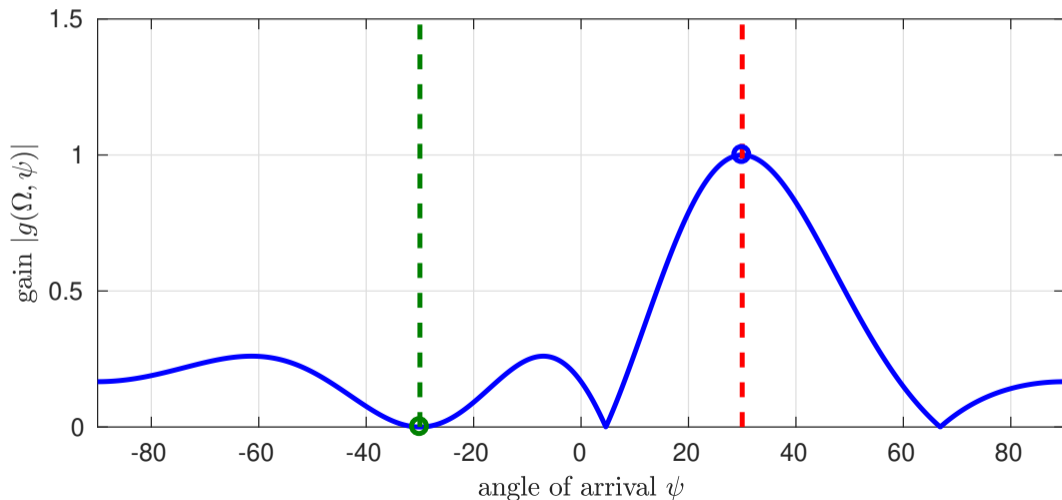

Beamforming Example — Variable Interferer I

- ▶ $M = 5$ sensors, source of interest towards $\theta_0 = 30^\circ$, interferer variable:

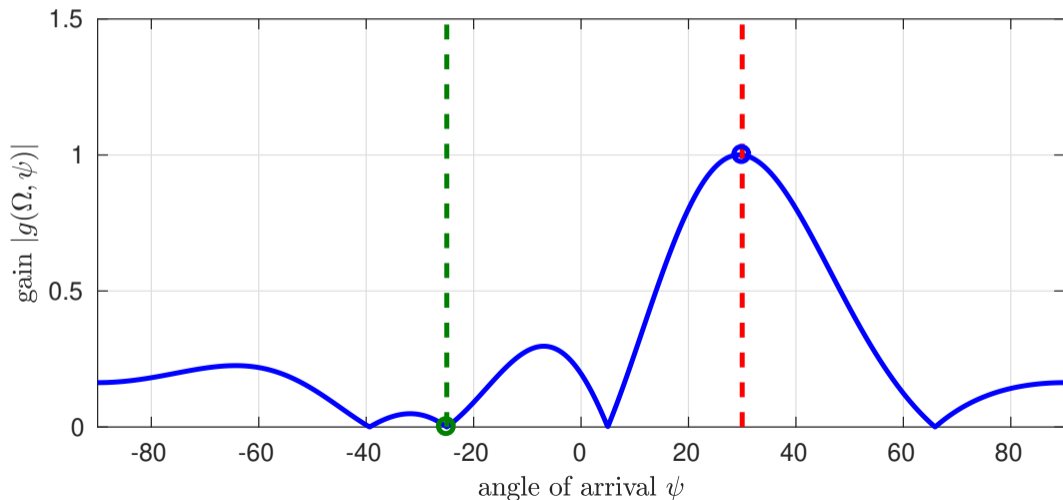

Beamforming Example — Variable Interferer I

- ▶ $M = 5$ sensors, source of interest towards $\theta_0 = 30^\circ$, interferer variable:

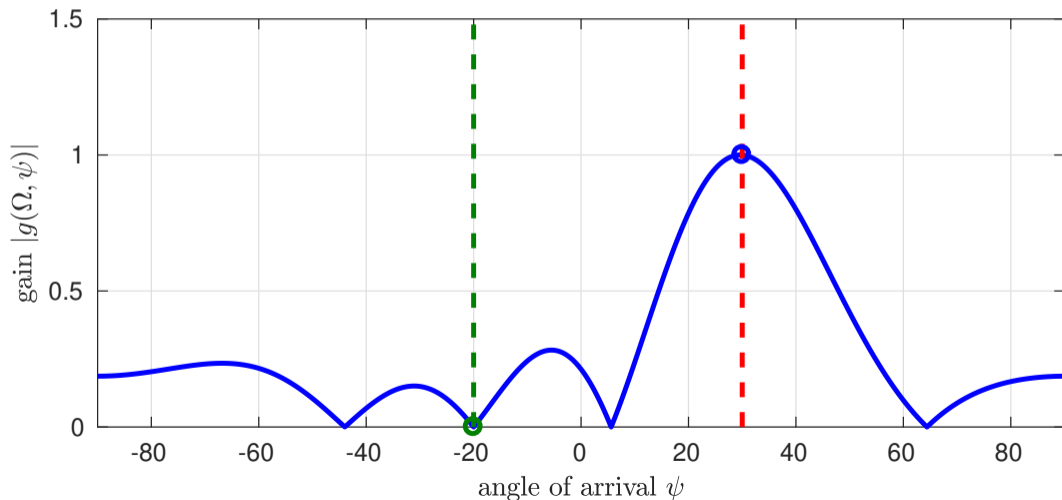

Beamforming Example — Variable Interferer I

- ▶ $M = 5$ sensors, source of interest towards $\theta_0 = 30^\circ$, interferer variable:

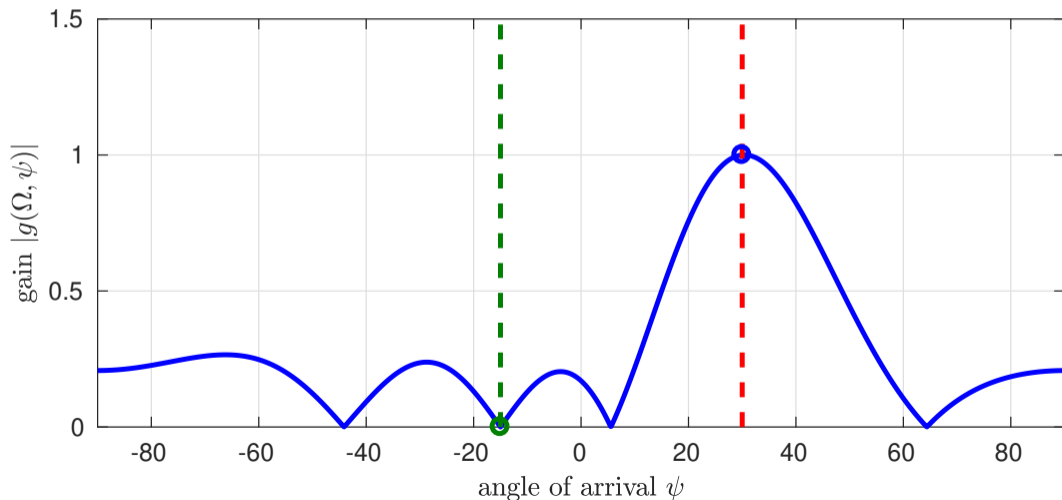

Beamforming Example — Variable Interferer I

- ▶ $M = 5$ sensors, source of interest towards $\theta_0 = 30^\circ$, interferer variable:

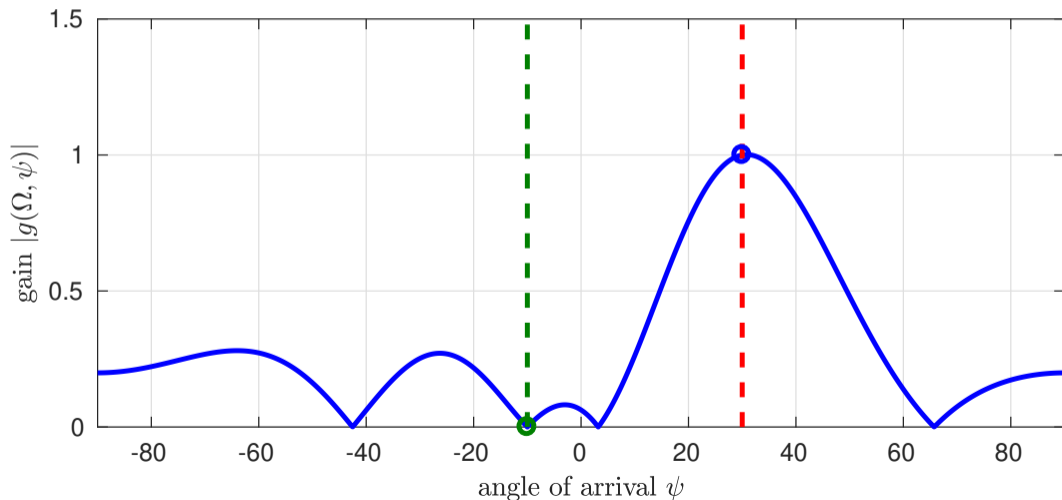

Beamforming Example — Variable Interferer I

- ▶ $M = 5$ sensors, source of interest towards $\theta_0 = 30^\circ$, interferer variable:

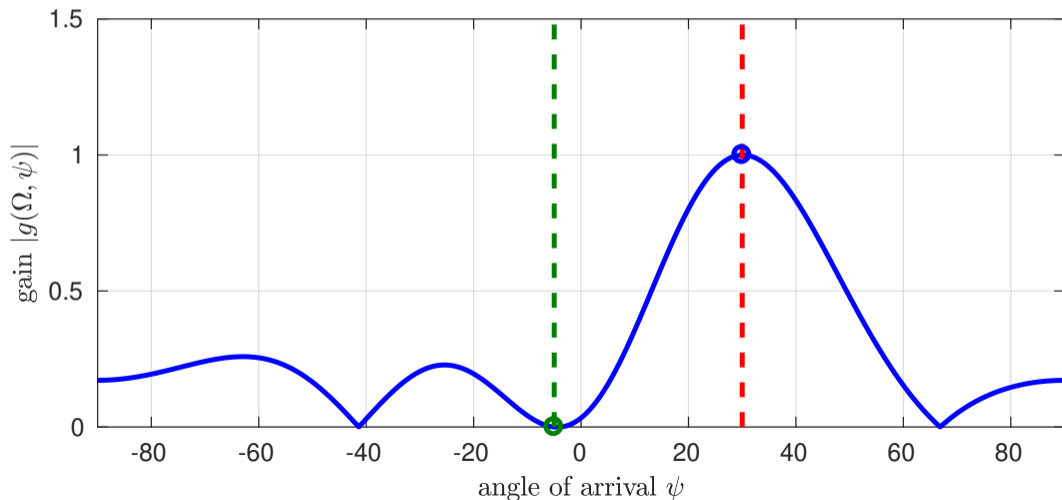

Beamforming Example — Variable Interferer I

- ▶ $M = 5$ sensors, source of interest towards $\theta_0 = 30^\circ$, interferer variable:

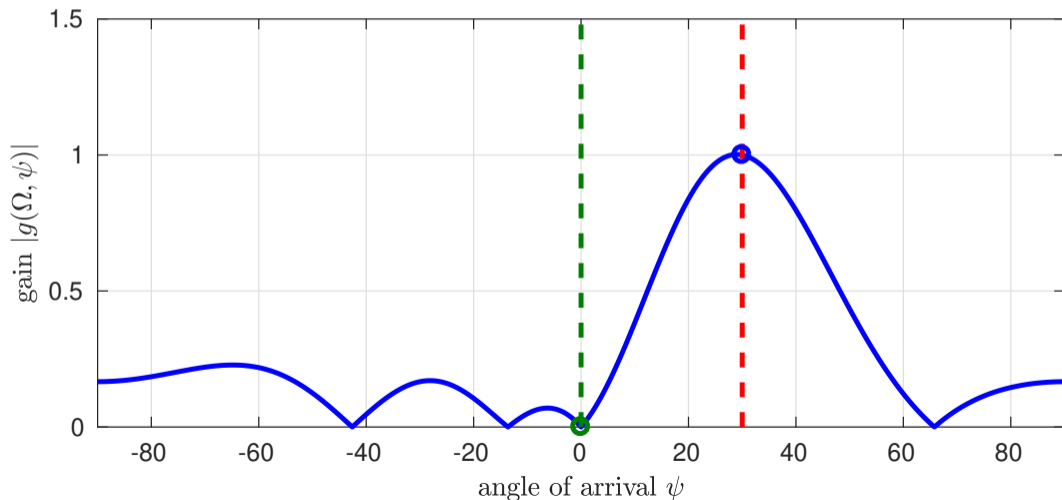

Beamforming Example — Variable Interferer I

- ▶ $M = 5$ sensors, source of interest towards $\theta_0 = 30^\circ$, interferer variable:

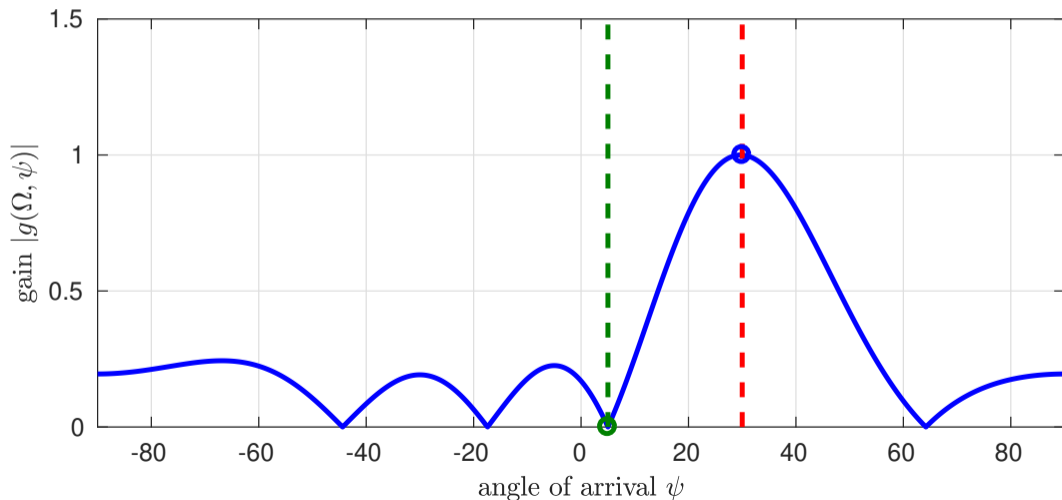

Beamforming Example — Variable Interferer I

- ▶ $M = 5$ sensors, source of interest towards $\theta_0 = 30^\circ$, interferer variable:

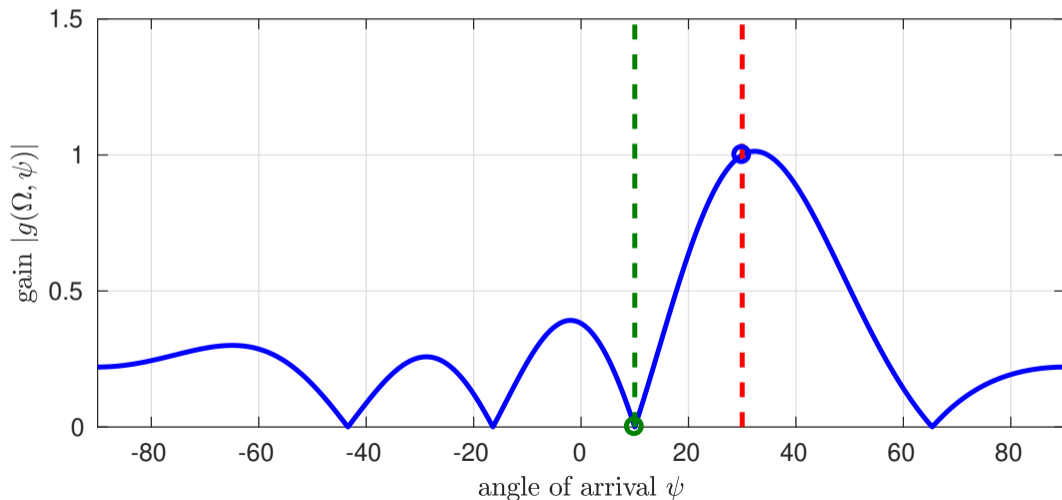

Beamforming Example — Variable Interferer I

- ▶ $M = 5$ sensors, source of interest towards $\theta_0 = 30^\circ$, interferer variable:

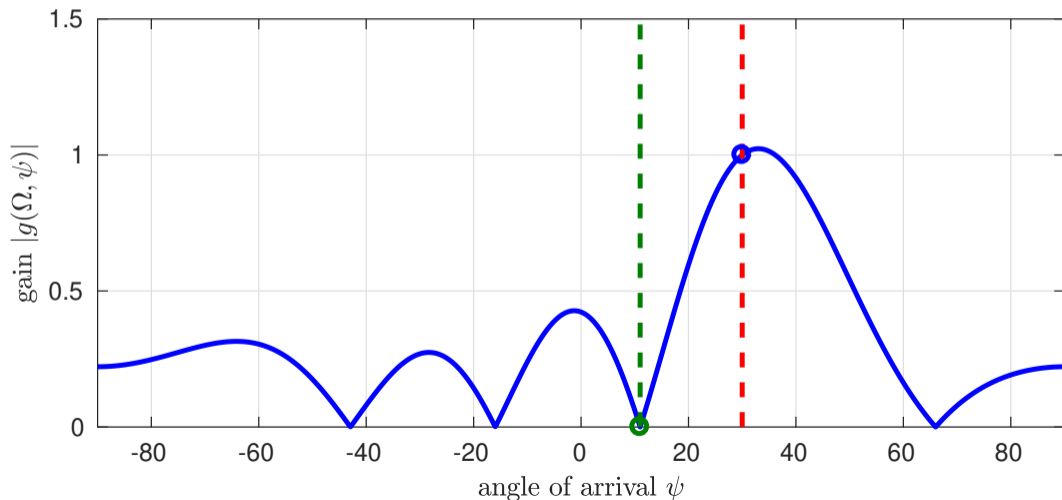

Beamforming Example — Variable Interferer I

- ▶ $M = 5$ sensors, source of interest towards $\theta_0 = 30^\circ$, interferer variable:

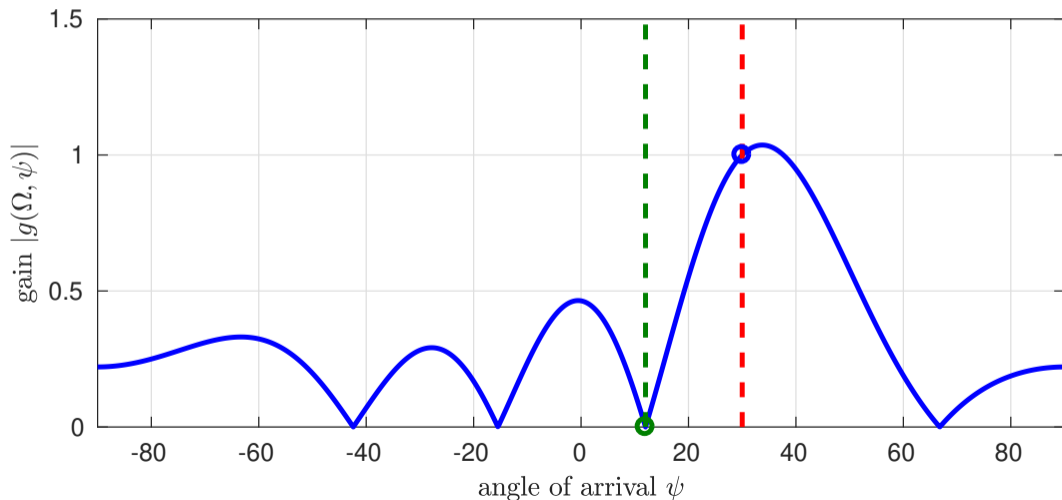

Beamforming Example — Variable Interferer I

- ▶ $M = 5$ sensors, source of interest towards $\theta_0 = 30^\circ$, interferer variable:

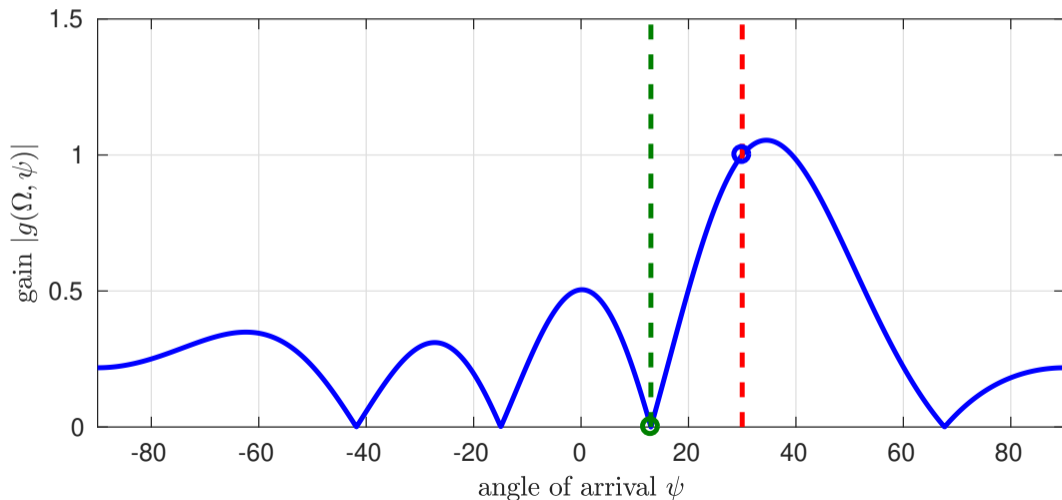

Beamforming Example — Variable Interferer I

- ▶ $M = 5$ sensors, source of interest towards $\theta_0 = 30^\circ$, interferer variable:

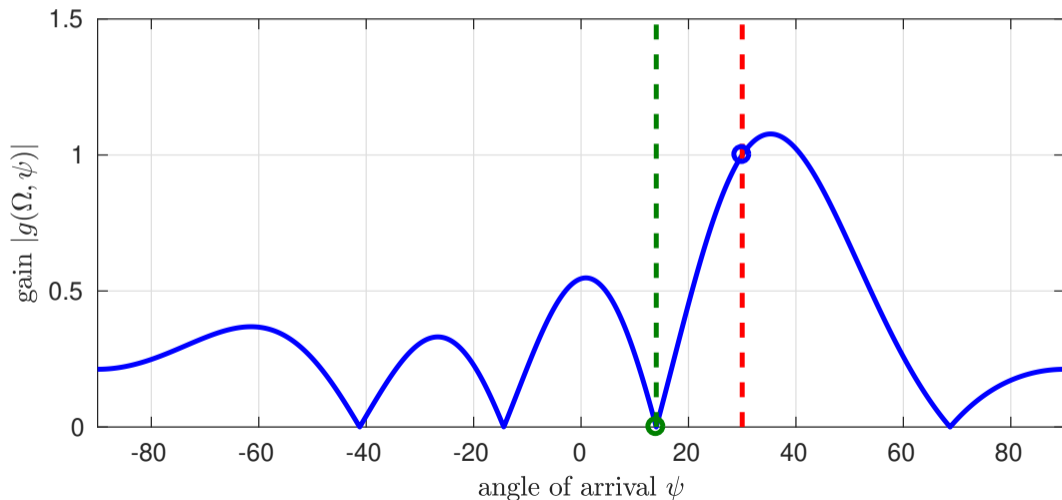

Beamforming Example — Variable Interferer I

- ▶ $M = 5$ sensors, source of interest towards $\theta_0 = 30^\circ$, interferer variable:

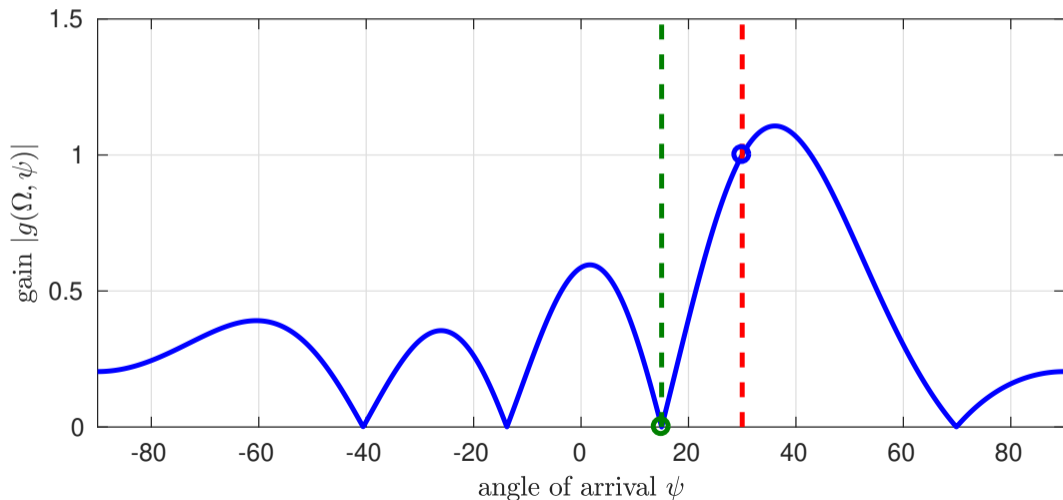

Beamforming Example — Variable Interferer I

- ▶ $M = 5$ sensors, source of interest towards $\theta_0 = 30^\circ$, interferer variable:

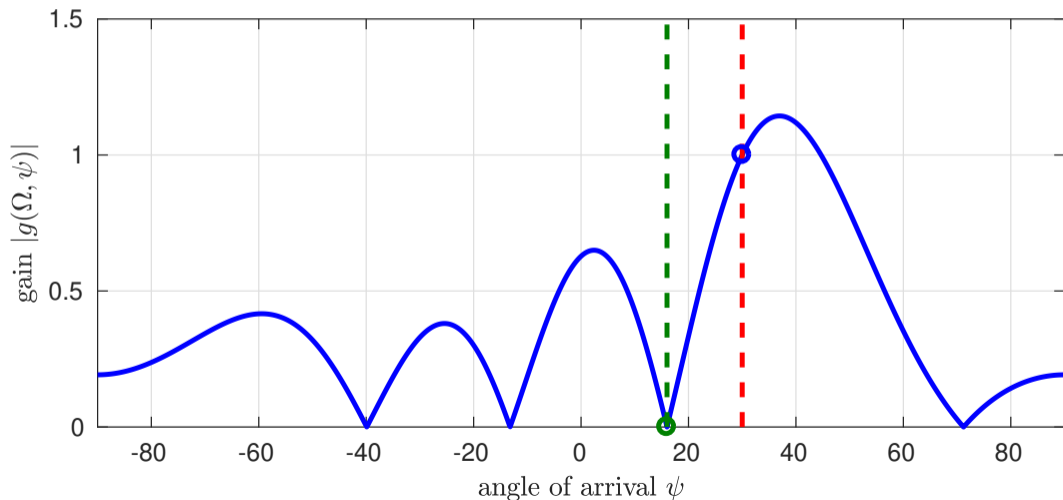

Beamforming Example — Variable Interferer I

- ▶ $M = 5$ sensors, source of interest towards $\theta_0 = 30^\circ$, interferer variable:

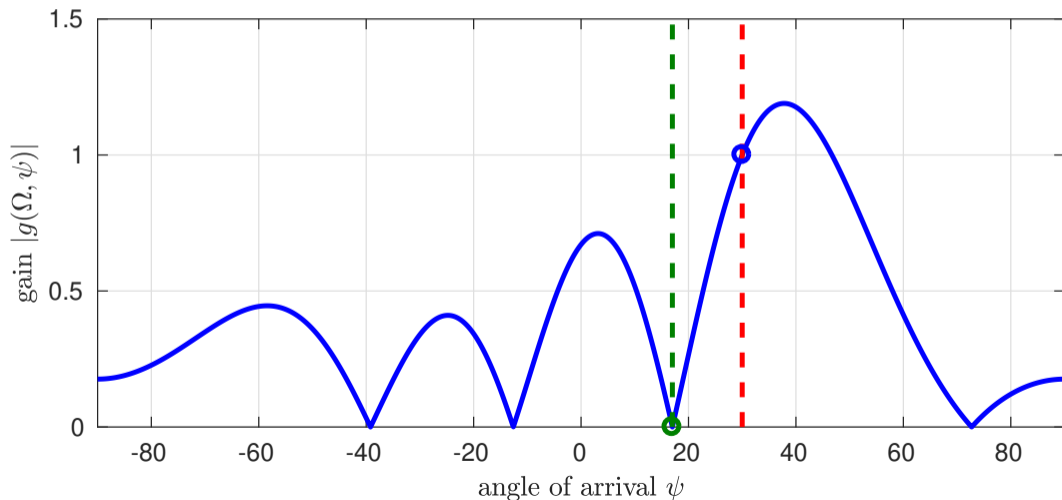

Beamforming Example — Variable Interferer I

- ▶ $M = 5$ sensors, source of interest towards $\theta_0 = 30^\circ$, interferer variable:

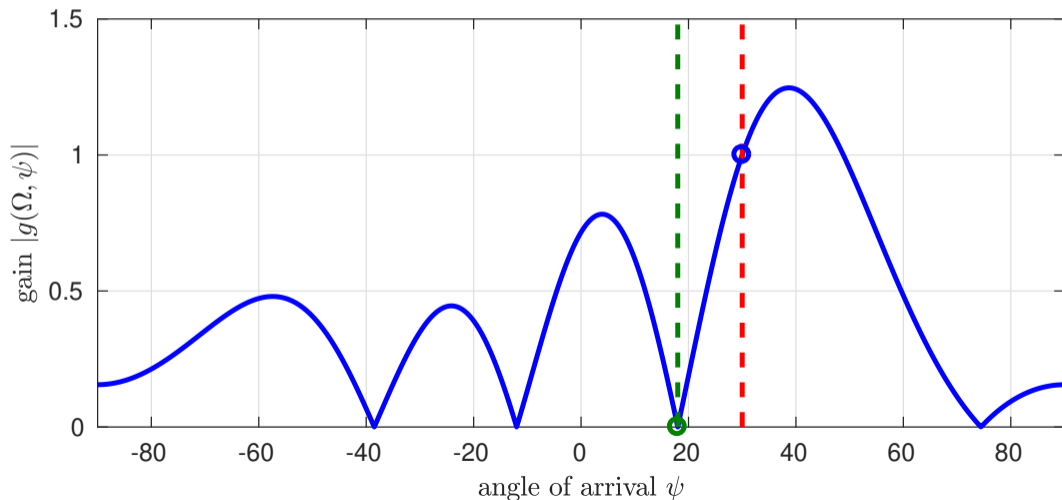

Beamforming Example — Variable Interferer I

- ▶ $M = 5$ sensors, source of interest towards $\theta_0 = 30^\circ$, interferer variable:

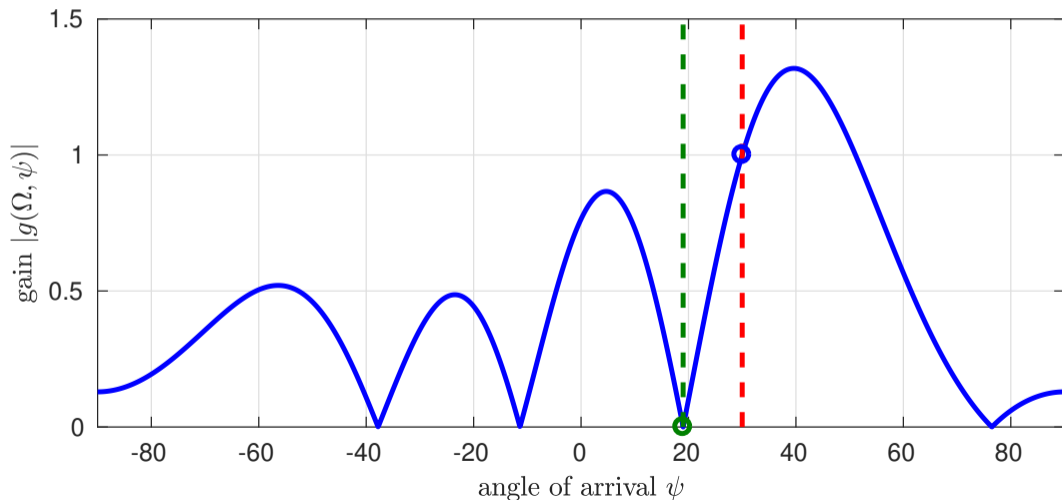

Beamforming Example — Variable Interferer I

- ▶ $M = 5$ sensors, source of interest towards $\theta_0 = 30^\circ$, interferer variable:

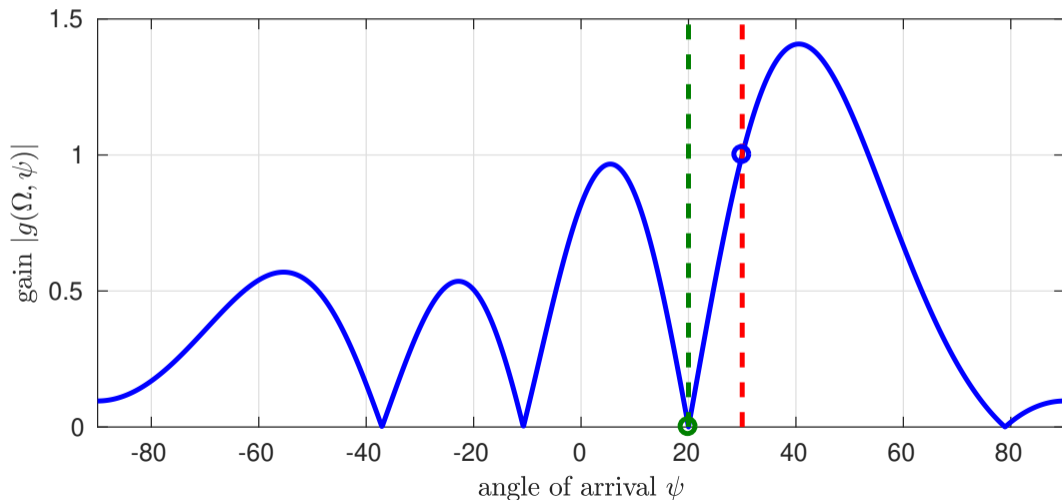

Beamforming Example — Variable Interferer I

- ▶ $M = 5$ sensors, source of interest towards $\theta_0 = 30^\circ$, interferer variable:

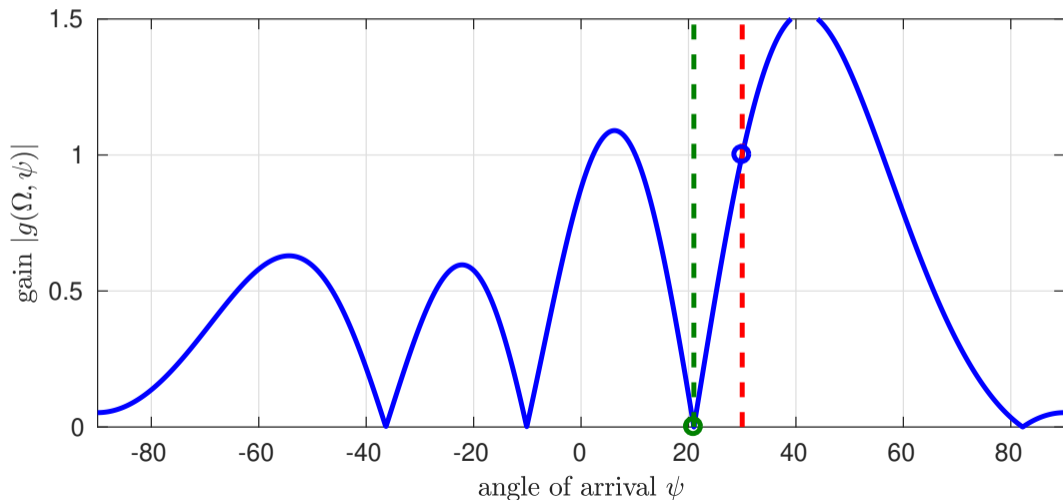

Beamforming Example — Variable Interferer I

- ▶ $M = 5$ sensors, source of interest towards $\theta_0 = 30^\circ$, interferer variable:

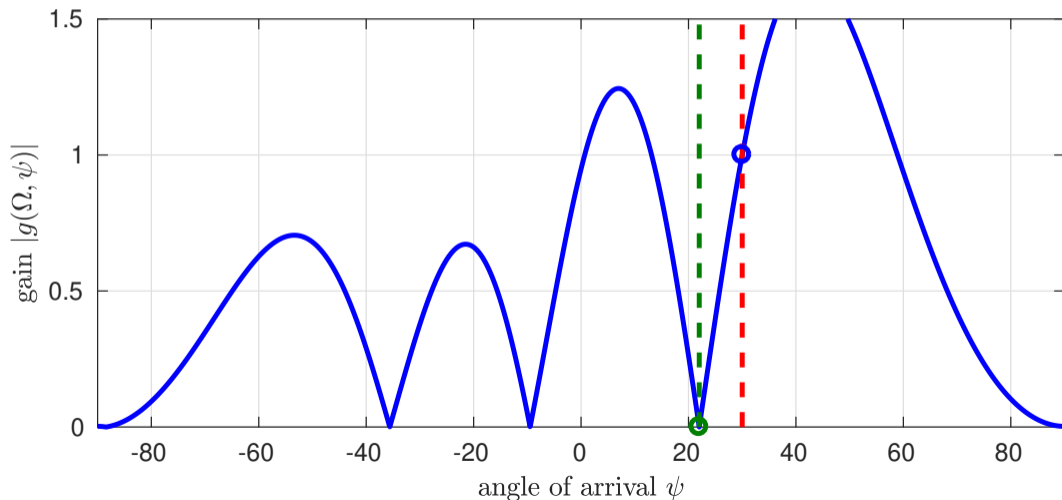

Beamforming Example — Variable Interferer I

- ▶ $M = 5$ sensors, source of interest towards $\theta_0 = 30^\circ$, interferer variable:

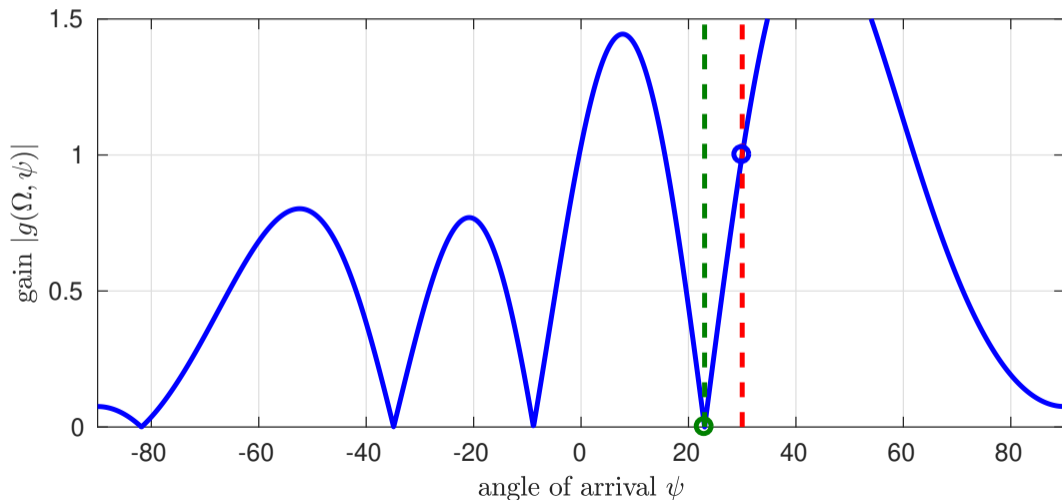

Beamforming Example — Variable Interferer I

- ▶ $M = 5$ sensors, source of interest towards $\theta_0 = 30^\circ$, interferer variable:

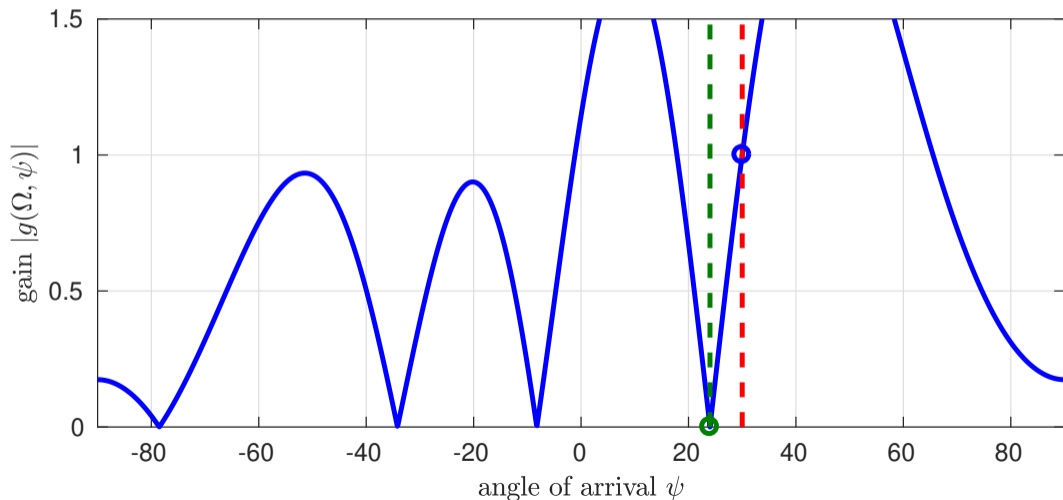

Beamforming Example — Variable Interferer I

- ▶ $M = 5$ sensors, source of interest towards $\theta_0 = 30^\circ$, interferer variable:

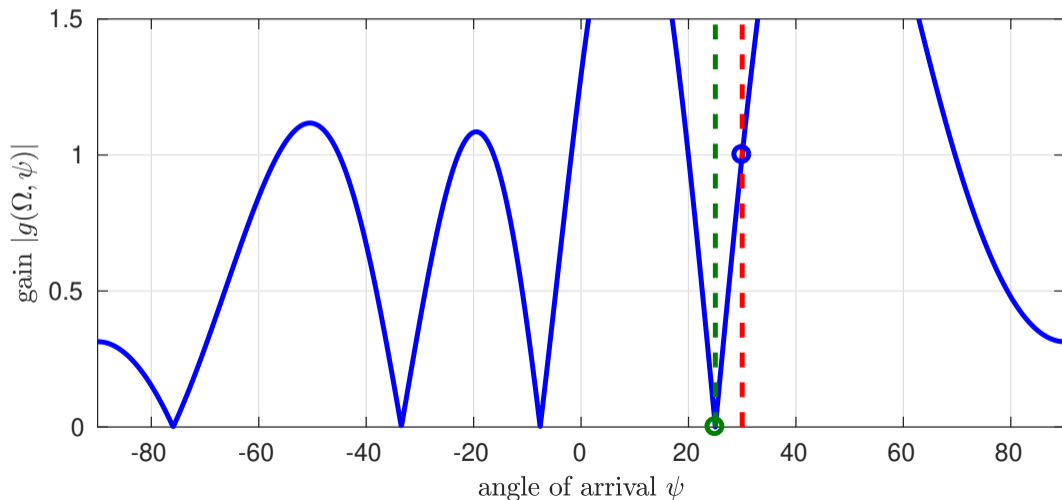

Beamforming Example — Variable Interferer II

- ▶ $M = 5$ sensors, SOI $\theta_0 = 30^\circ$, one fixed and one variable interferer:

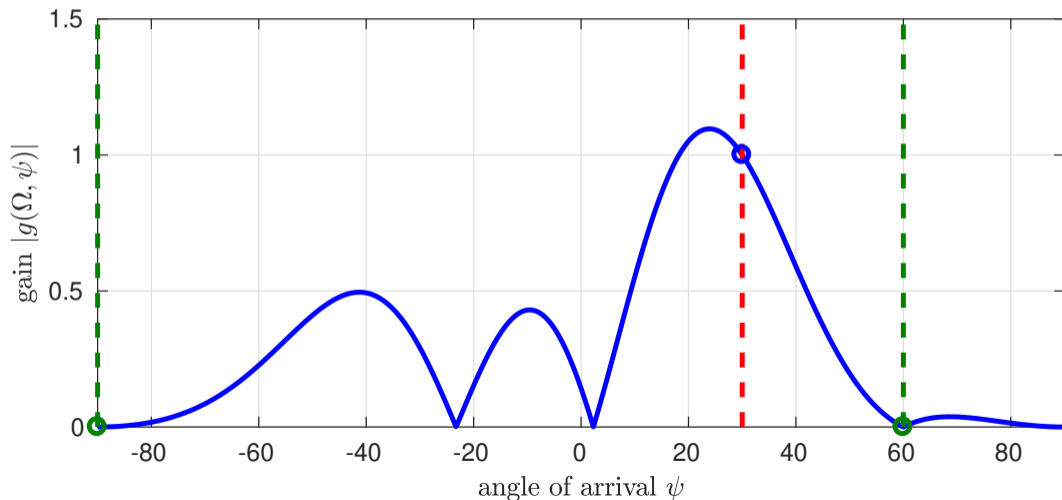

Beamforming Example — Variable Interferer II

- ▶ $M = 5$ sensors, SOI $\theta_0 = 30^\circ$, one fixed and one variable interferer:

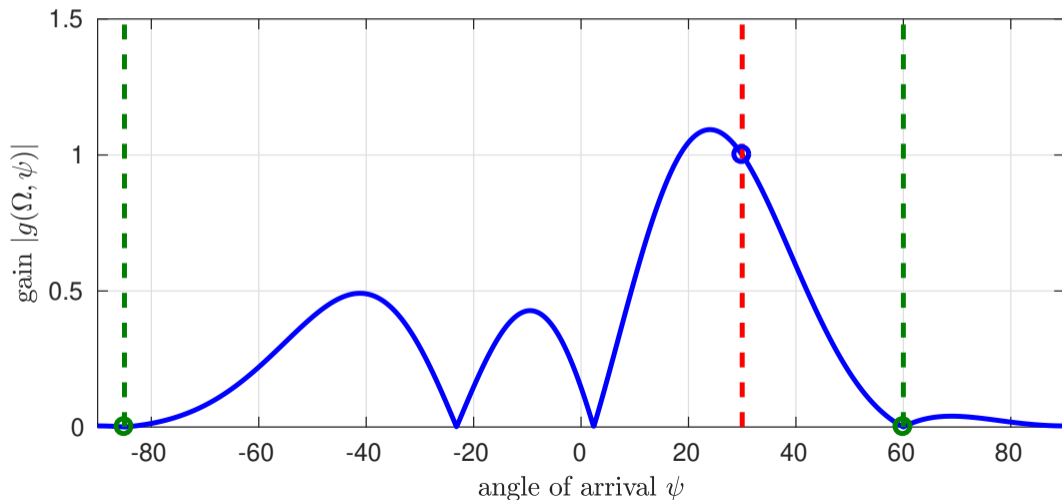

Beamforming Example — Variable Interferer II

- ▶ $M = 5$ sensors, SOI $\theta_0 = 30^\circ$, one fixed and one variable interferer:

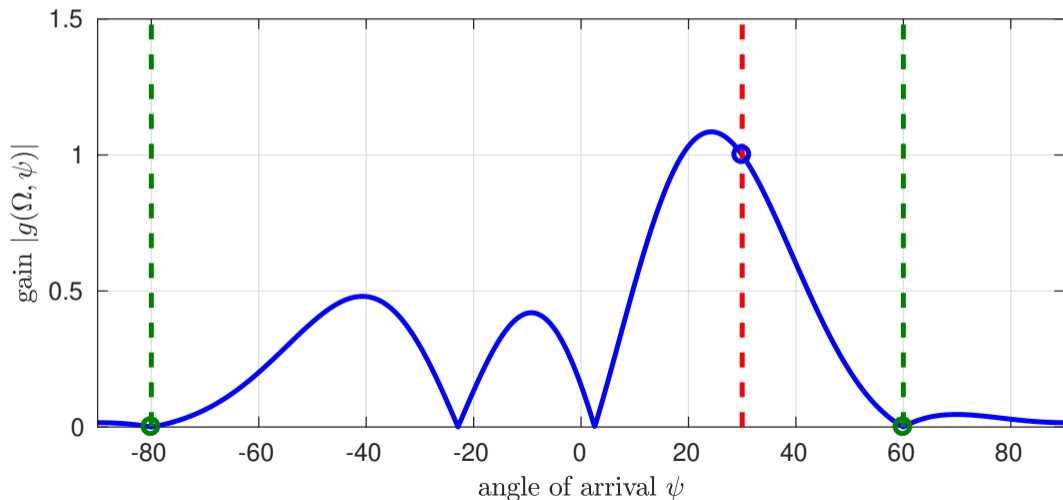

Beamforming Example — Variable Interferer II

- ▶ $M = 5$ sensors, SOI $\theta_0 = 30^\circ$, one fixed and one variable interferer:

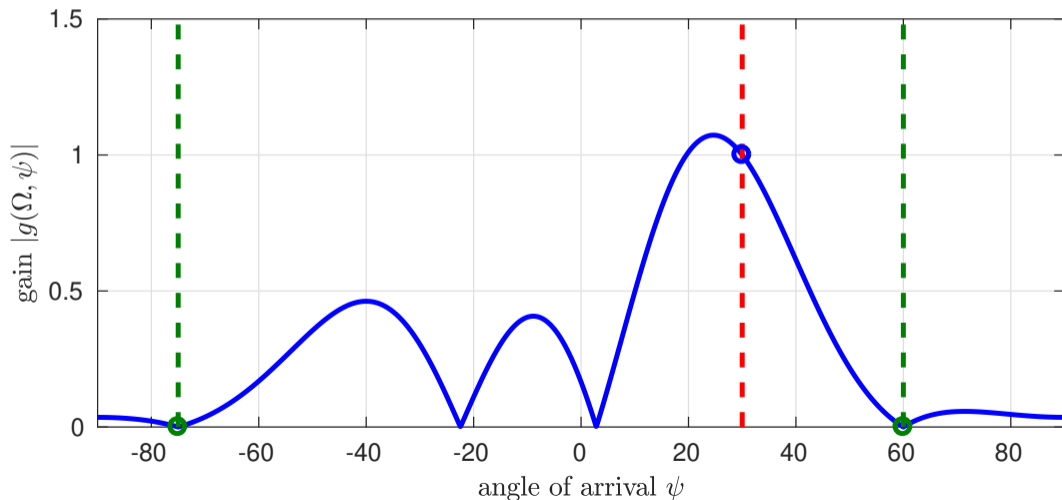

Beamforming Example — Variable Interferer II

- ▶ $M = 5$ sensors, SOI $\theta_0 = 30^\circ$, one fixed and one variable interferer:

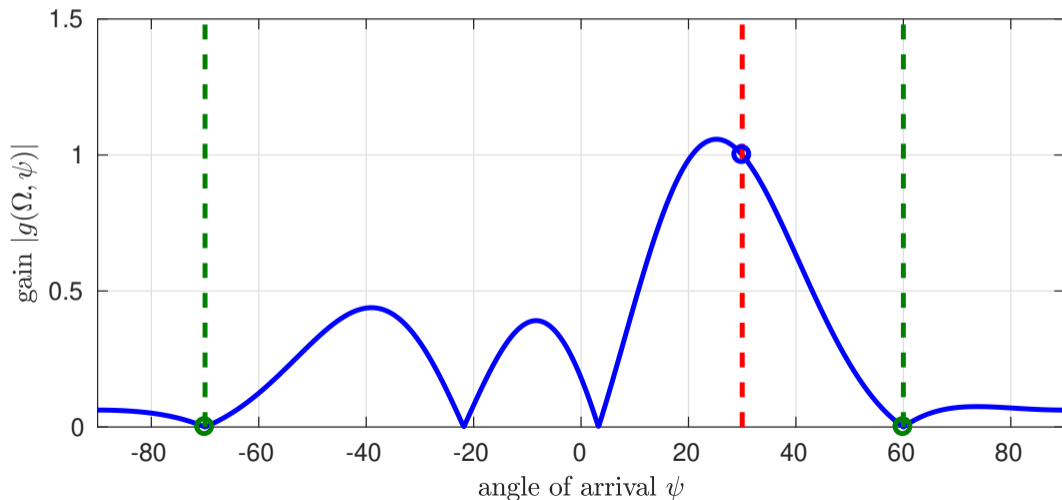

Beamforming Example — Variable Interferer II

- ▶ $M = 5$ sensors, SOI $\theta_0 = 30^\circ$, one fixed and one variable interferer:

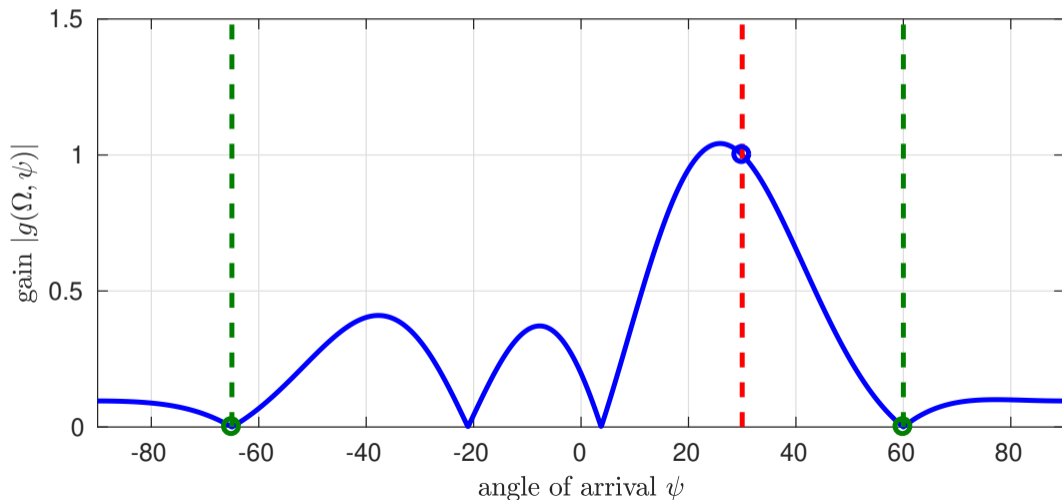

Beamforming Example — Variable Interferer II

- ▶ $M = 5$ sensors, SOI $\theta_0 = 30^\circ$, one fixed and one variable interferer:

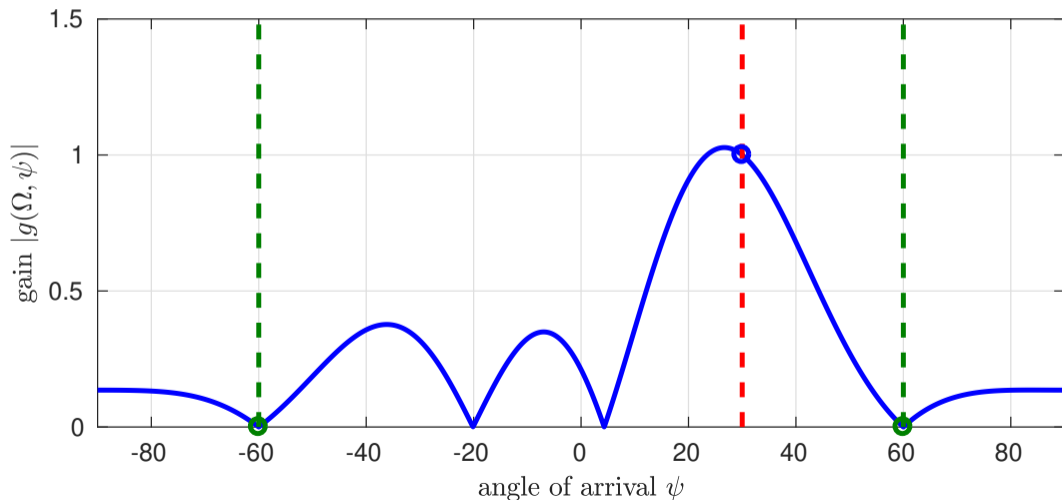

Beamforming Example — Variable Interferer II

- ▶ $M = 5$ sensors, SOI $\theta_0 = 30^\circ$, one fixed and one variable interferer:

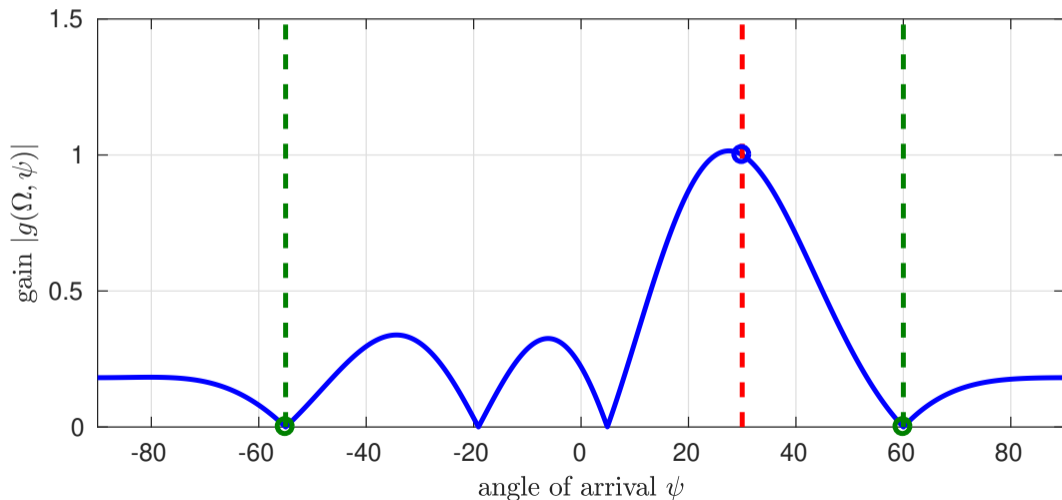

Beamforming Example — Variable Interferer II

- ▶ $M = 5$ sensors, SOI $\theta_0 = 30^\circ$, one fixed and one variable interferer:

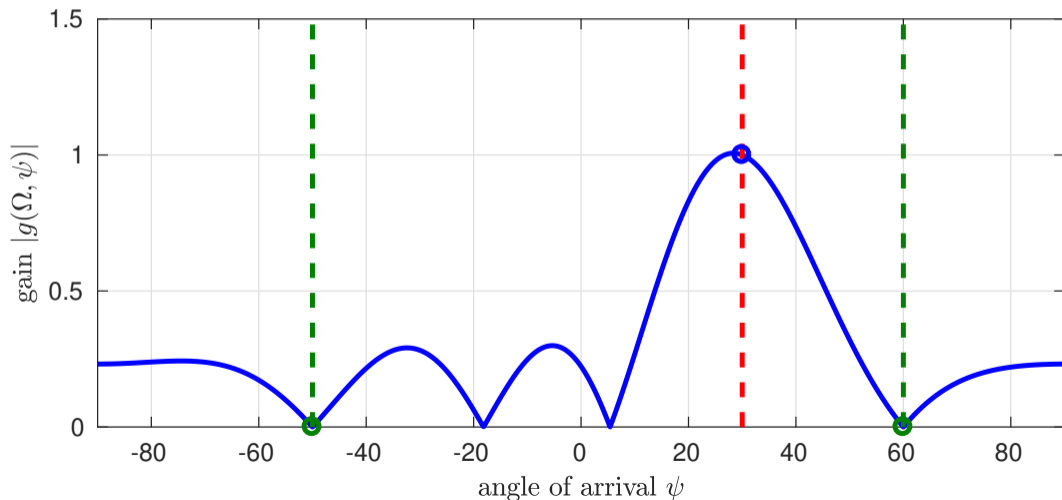

Beamforming Example — Variable Interferer II

- ▶ $M = 5$ sensors, SOI $\theta_0 = 30^\circ$, one fixed and one variable interferer:

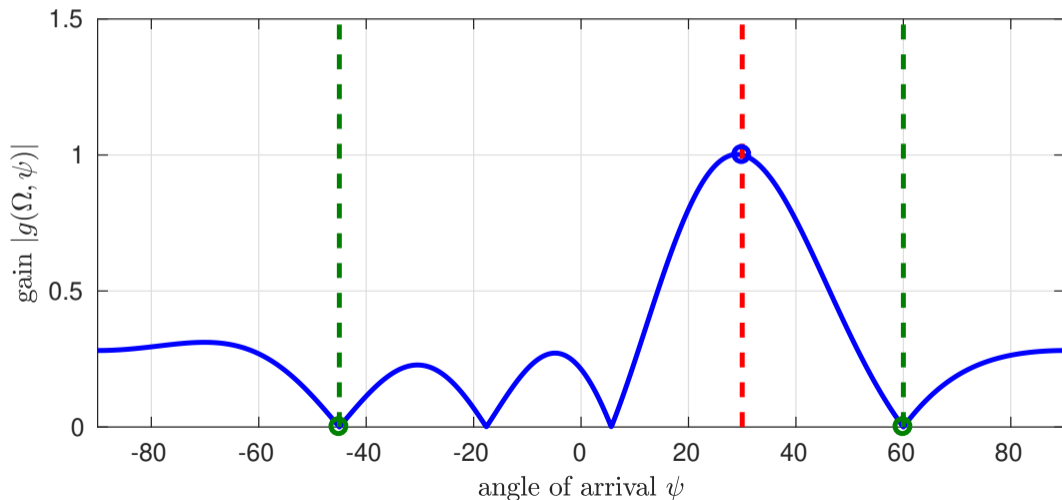

Beamforming Example — Variable Interferer II

- ▶ $M = 5$ sensors, SOI $\theta_0 = 30^\circ$, one fixed and one variable interferer:

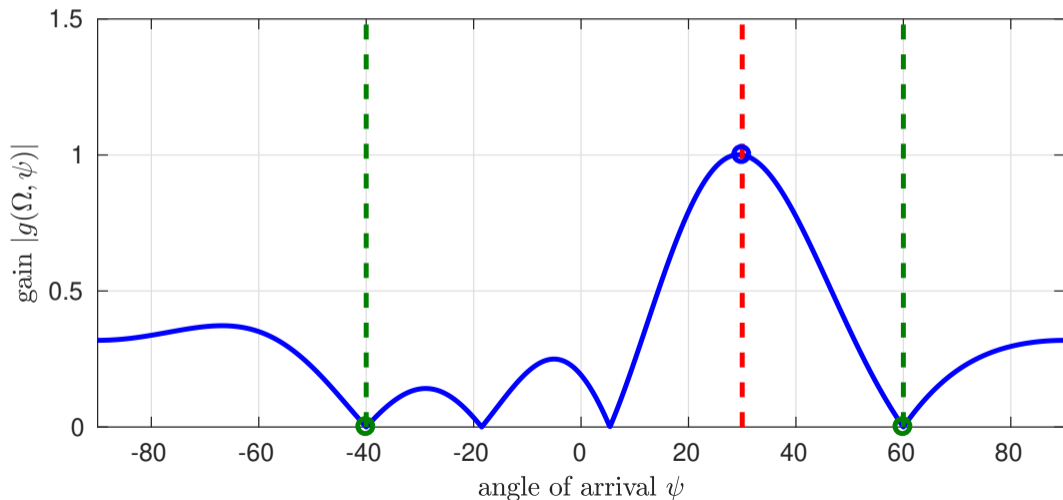

Beamforming Example — Variable Interferer II

- ▶ $M = 5$ sensors, SOI $\theta_0 = 30^\circ$, one fixed and one variable interferer:

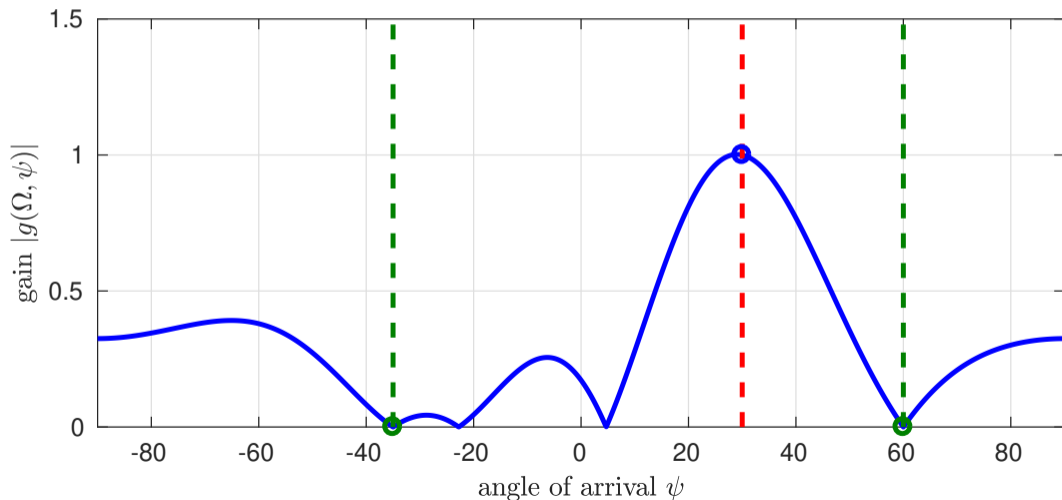

Beamforming Example — Variable Interferer II

- ▶ $M = 5$ sensors, SOI $\theta_0 = 30^\circ$, one fixed and one variable interferer:

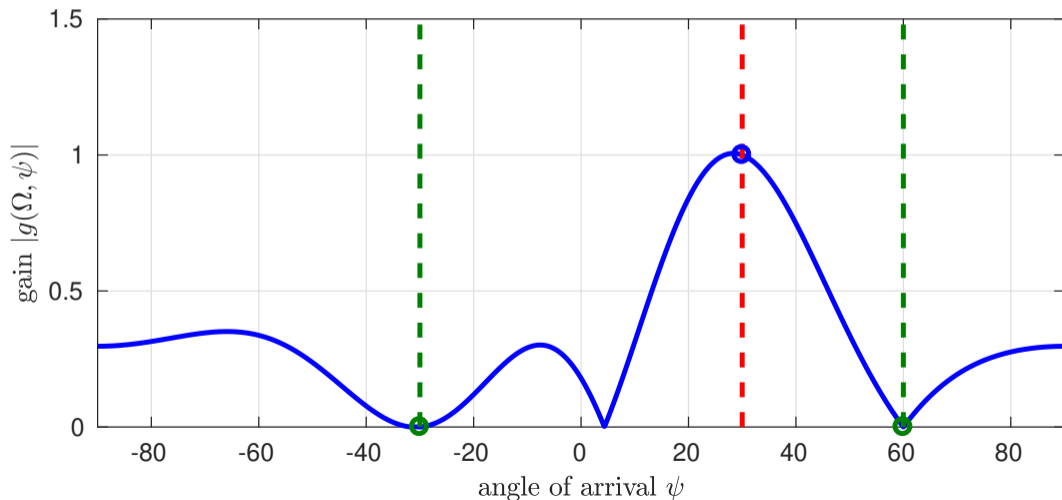

Beamforming Example — Variable Interferer II

- ▶ $M = 5$ sensors, SOI $\theta_0 = 30^\circ$, one fixed and one variable interferer:

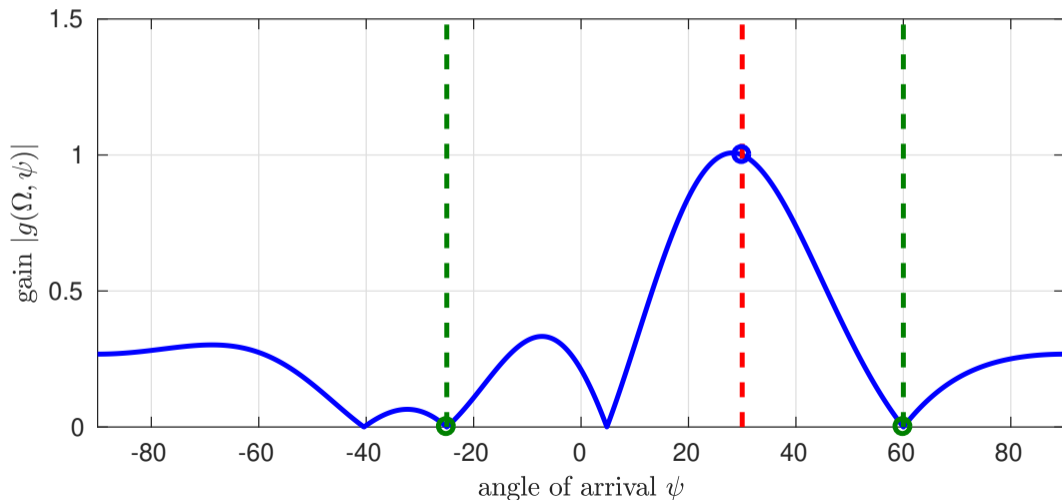

Beamforming Example — Variable Interferer II

- ▶ $M = 5$ sensors, SOI $\theta_0 = 30^\circ$, one fixed and one variable interferer:

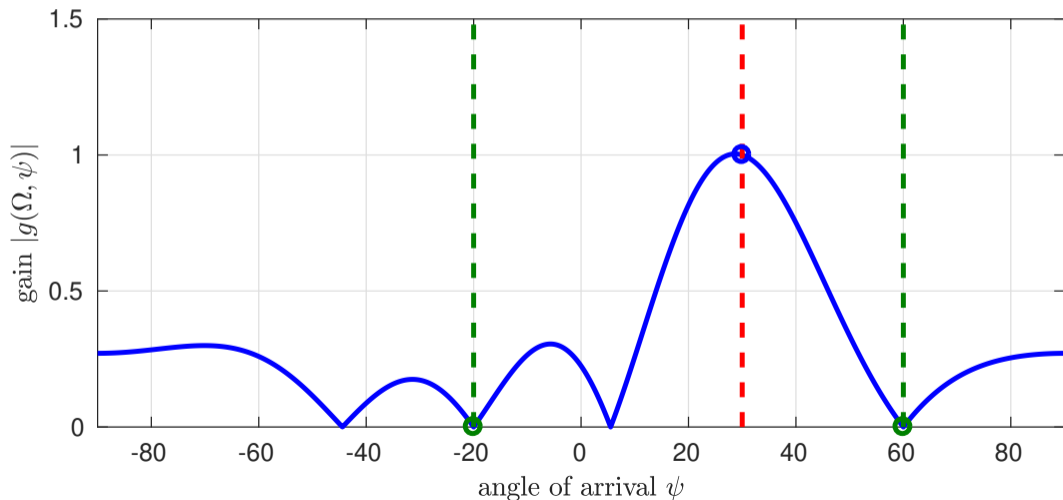

Beamforming Example — Variable Interferer II

- ▶ $M = 5$ sensors, SOI $\theta_0 = 30^\circ$, one fixed and one variable interferer:

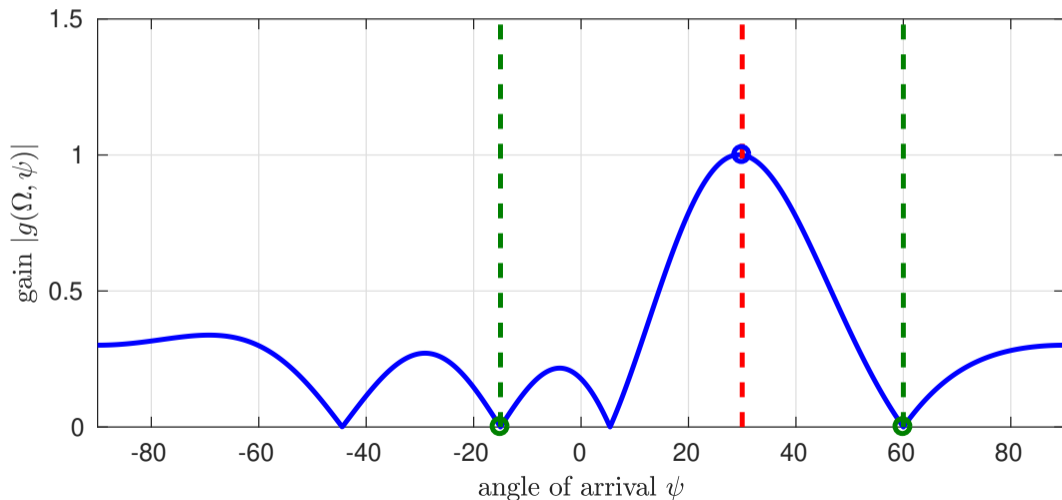

Beamforming Example — Variable Interferer II

- ▶ $M = 5$ sensors, SOI $\theta_0 = 30^\circ$, one fixed and one variable interferer:

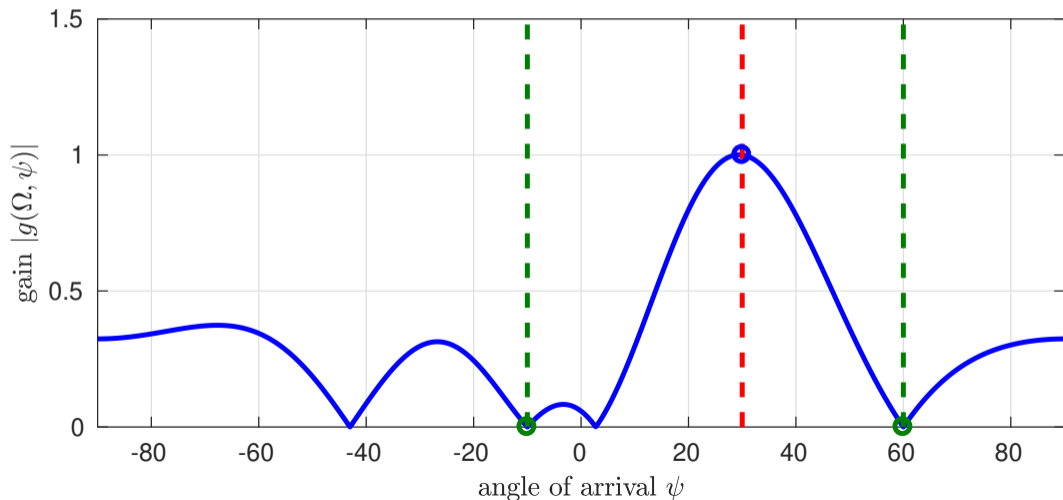

Beamforming Example — Variable Interferer II

- ▶ $M = 5$ sensors, SOI $\theta_0 = 30^\circ$, one fixed and one variable interferer:

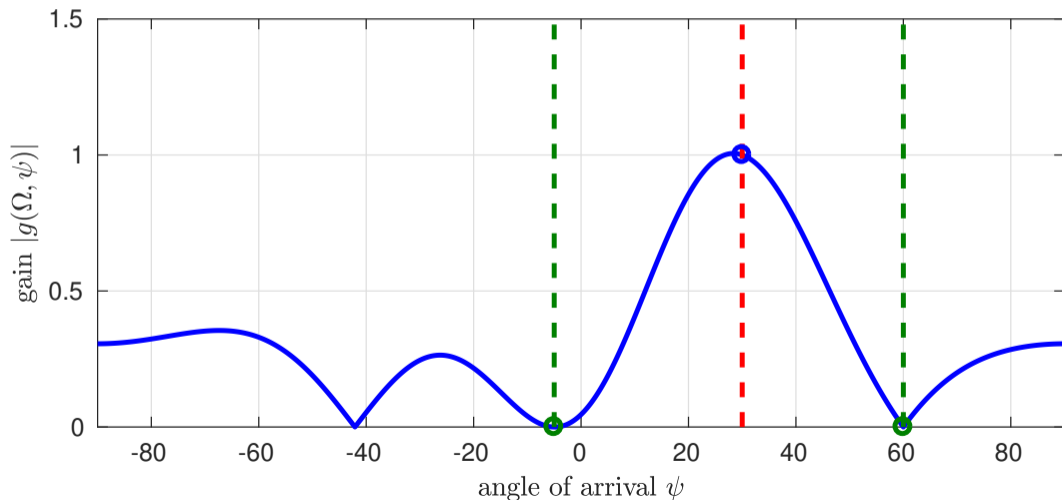

Beamforming Example — Variable Interferer II

- ▶ $M = 5$ sensors, SOI $\theta_0 = 30^\circ$, one fixed and one variable interferer:

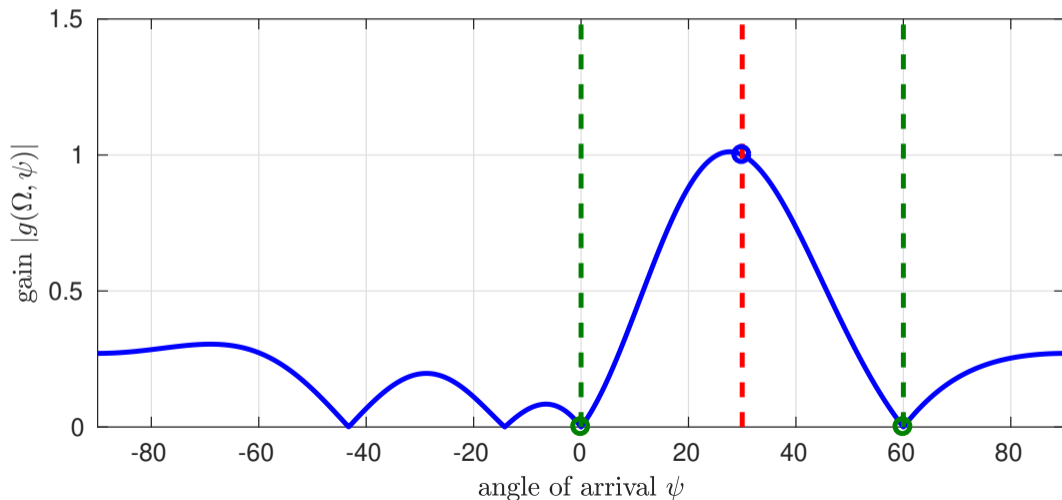

Beamforming Example — Variable Interferer II

- ▶ $M = 5$ sensors, SOI $\theta_0 = 30^\circ$, one fixed and one variable interferer:

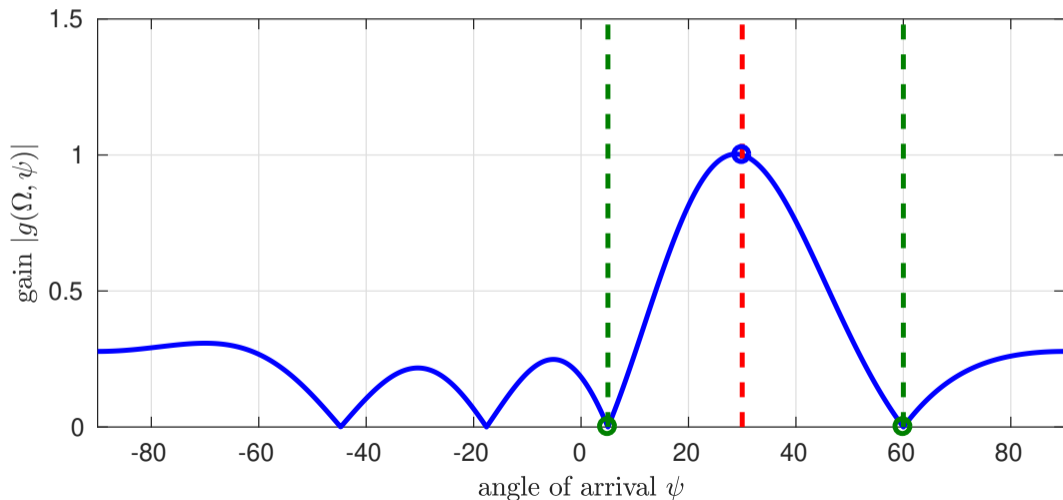

Beamforming Example — Variable Interferer II

- ▶ $M = 5$ sensors, SOI $\theta_0 = 30^\circ$, one fixed and one variable interferer:

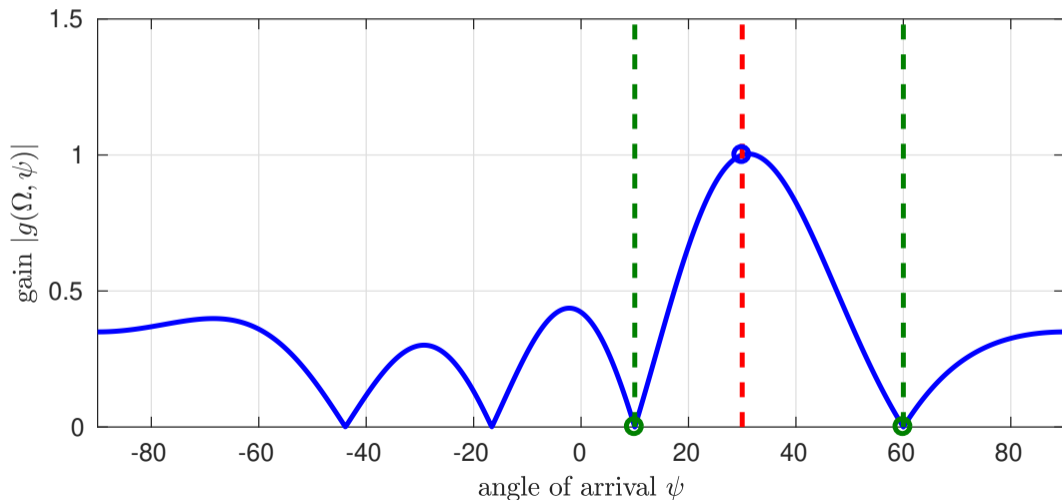

Beamforming Example — Variable Interferer II

- ▶ $M = 5$ sensors, SOI $\theta_0 = 30^\circ$, one fixed and one variable interferer:

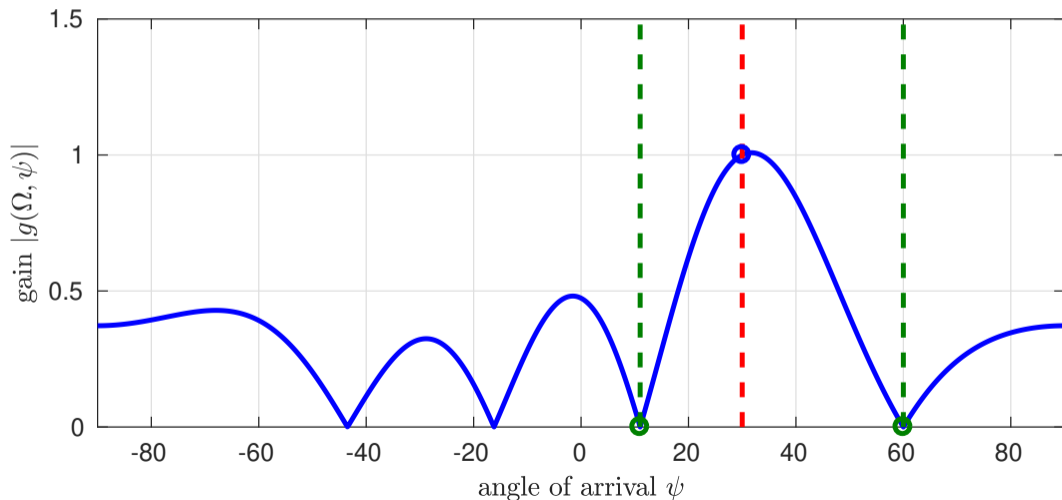

Beamforming Example — Variable Interferer II

- ▶ $M = 5$ sensors, SOI $\theta_0 = 30^\circ$, one fixed and one variable interferer:

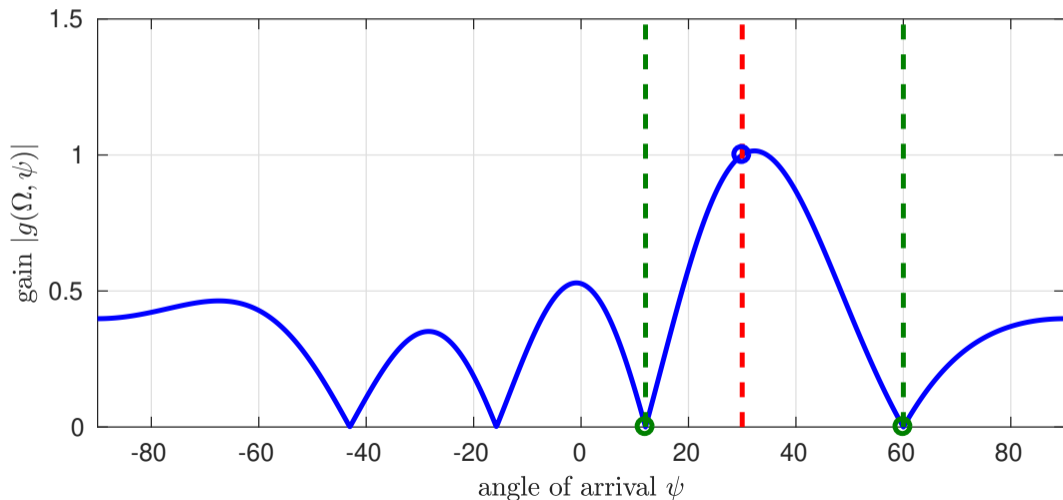

Beamforming Example — Variable Interferer II

- ▶ $M = 5$ sensors, SOI $\theta_0 = 30^\circ$, one fixed and one variable interferer:

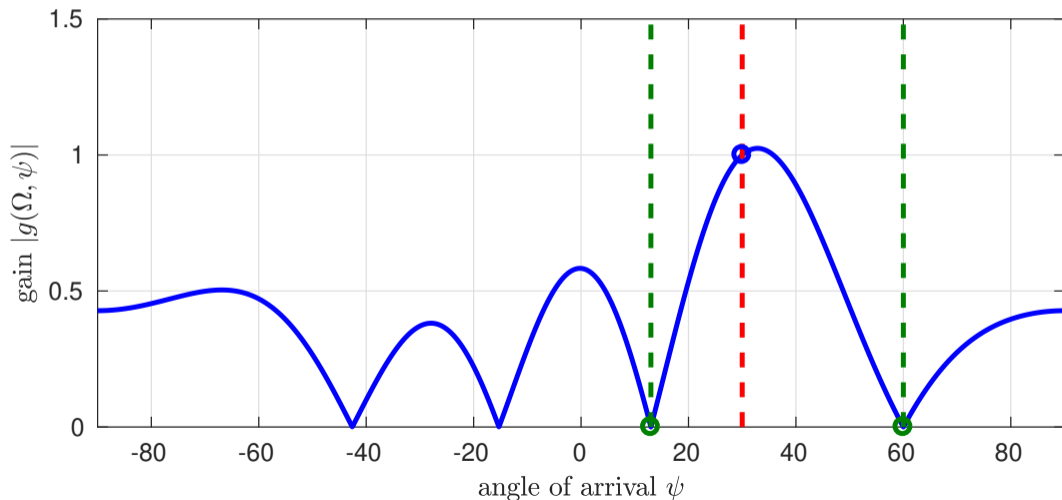

Beamforming Example — Variable Interferer II

- ▶ $M = 5$ sensors, SOI $\theta_0 = 30^\circ$, one fixed and one variable interferer:

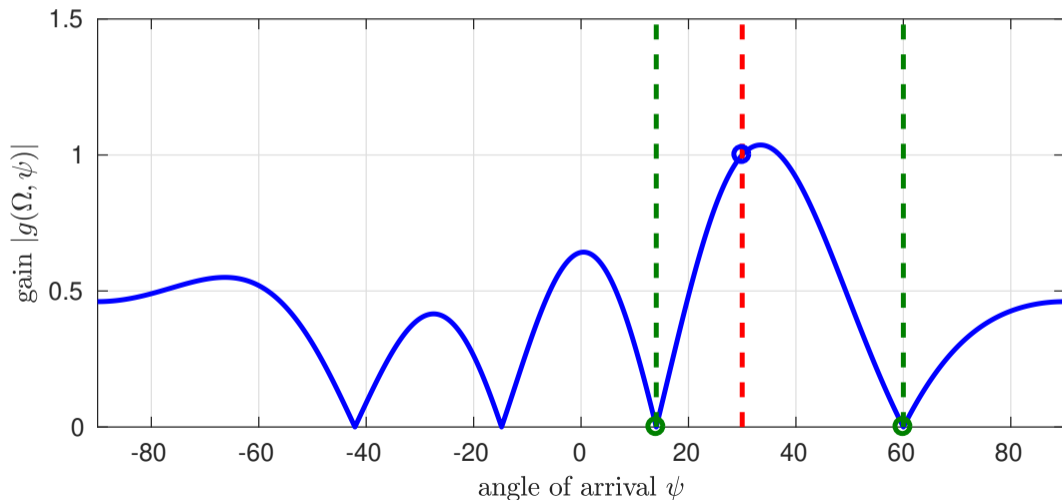

Beamforming Example — Variable Interferer II

- ▶ $M = 5$ sensors, SOI $\theta_0 = 30^\circ$, one fixed and one variable interferer:

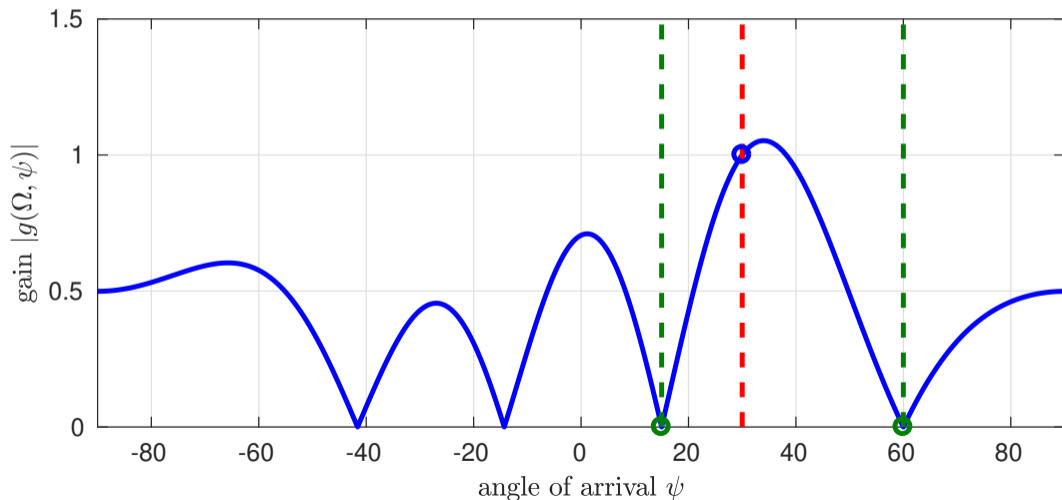

Beamforming Example — Variable Interferer II

- ▶ $M = 5$ sensors, SOI $\theta_0 = 30^\circ$, one fixed and one variable interferer:

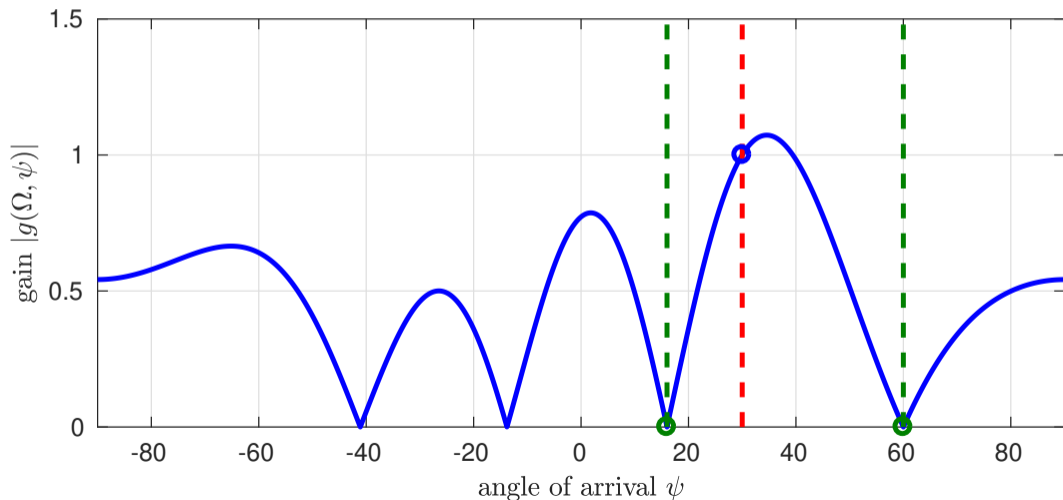

Beamforming Example — Variable Interferer II

- ▶ $M = 5$ sensors, SOI $\theta_0 = 30^\circ$, one fixed and one variable interferer:

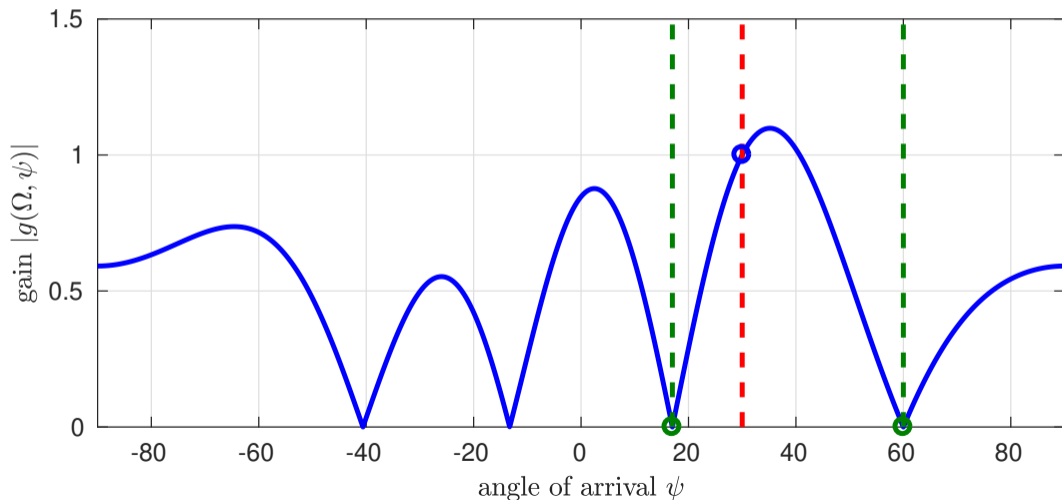

Beamforming Example — Variable Interferer II

- ▶ $M = 5$ sensors, SOI $\theta_0 = 30^\circ$, one fixed and one variable interferer:

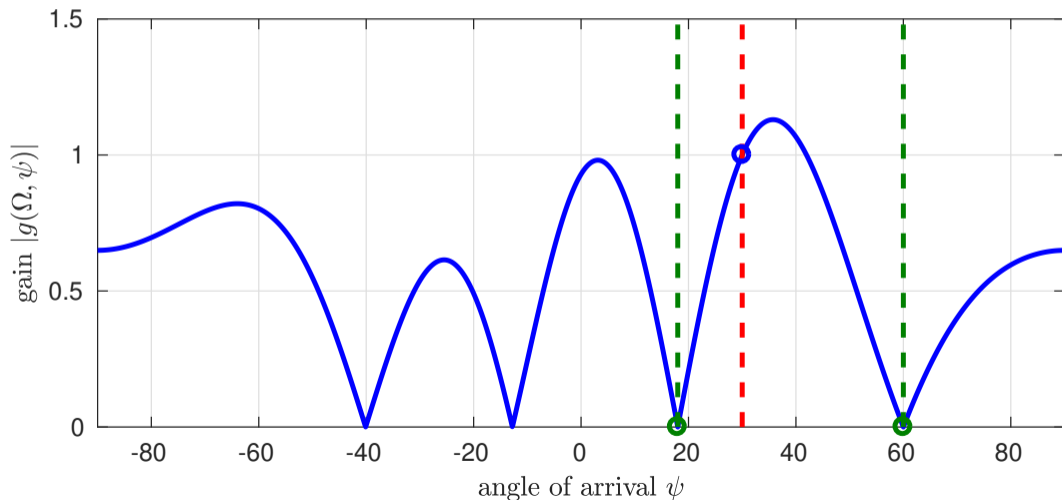

Beamforming Example — Variable Interferer II

- ▶ $M = 5$ sensors, SOI $\theta_0 = 30^\circ$, one fixed and one variable interferer:

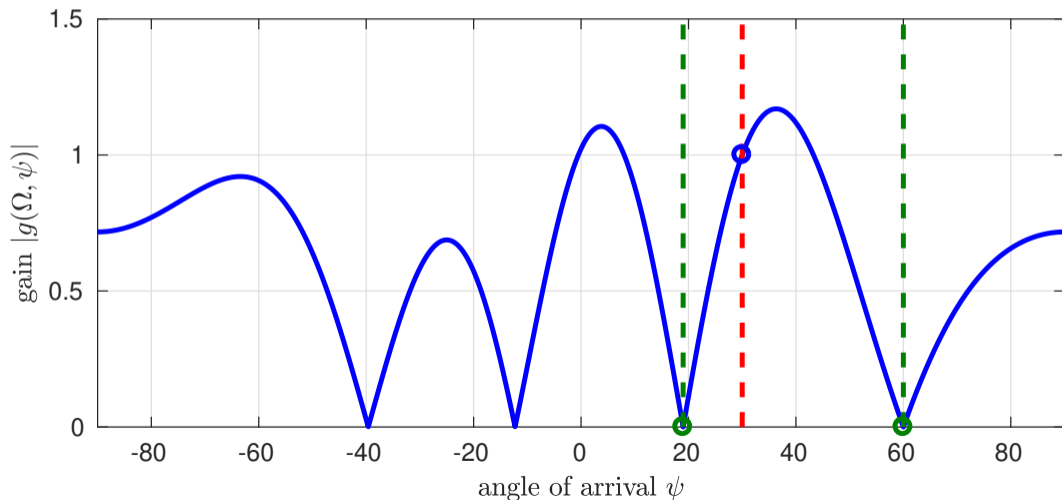

Beamforming Example — Variable Interferer II

- ▶ $M = 5$ sensors, SOI $\theta_0 = 30^\circ$, one fixed and one variable interferer:

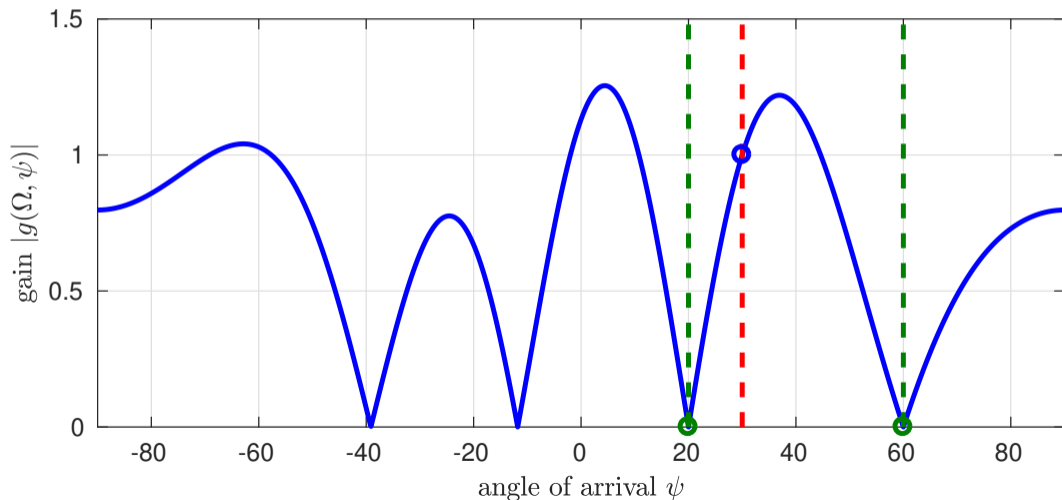

Beamforming Example — Variable Interferer II

- ▶ $M = 5$ sensors, SOI $\theta_0 = 30^\circ$, one fixed and one variable interferer:

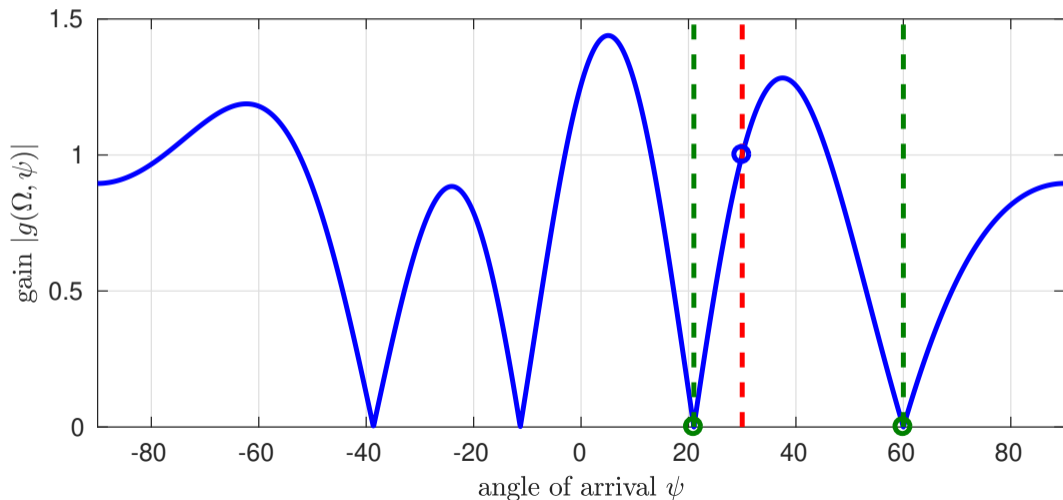

Beamforming Example — Variable Interferer II

- ▶ $M = 5$ sensors, SOI $\theta_0 = 30^\circ$, one fixed and one variable interferer:

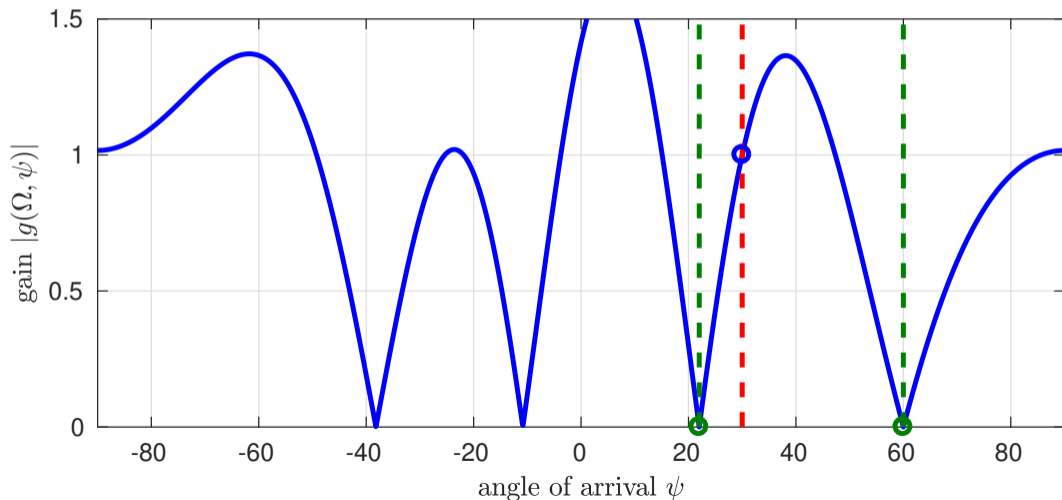

Beamforming Example — Variable Interferer II

- ▶ $M = 5$ sensors, SOI $\theta_0 = 30^\circ$, one fixed and one variable interferer:

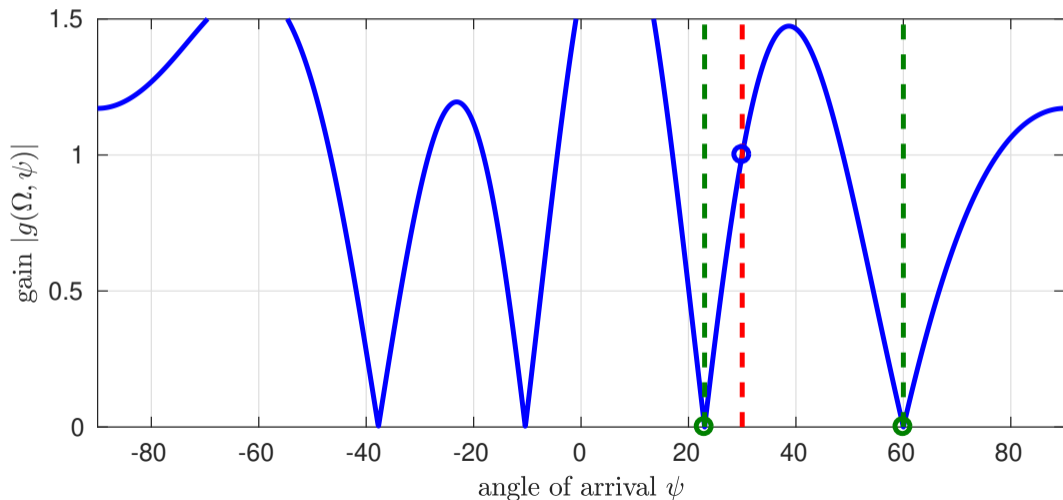

Beamforming Example — Variable Interferer II

- ▶ $M = 5$ sensors, SOI $\theta_0 = 30^\circ$, one fixed and one variable interferer:

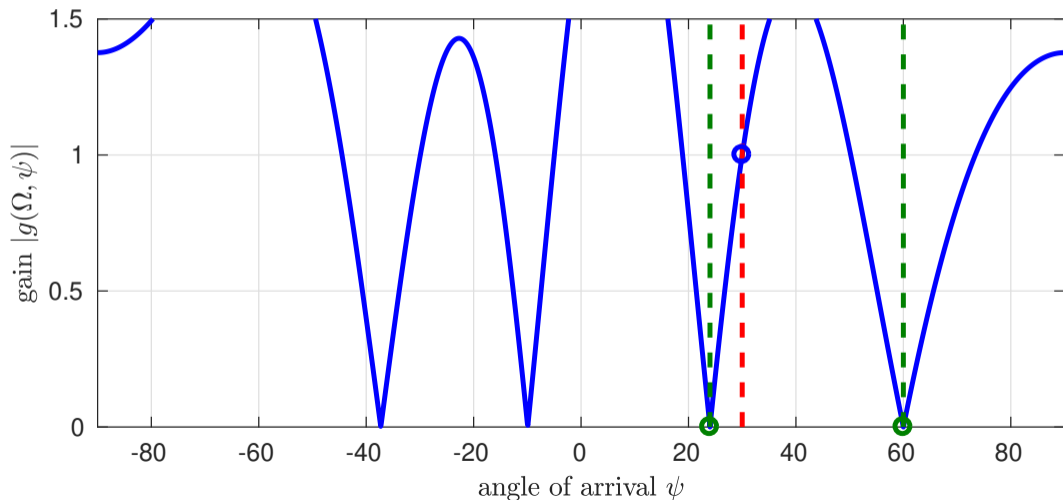

Beamforming Example — Variable Interferer II

- ▶ $M = 5$ sensors, SOI $\theta_0 = 30^\circ$, one fixed and one variable interferer:

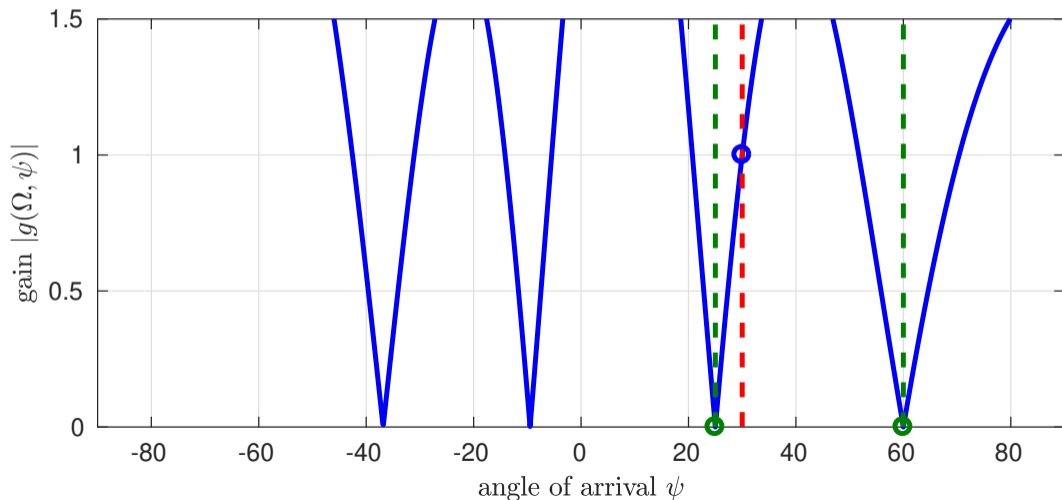

Beamforming Example — Variable Interferer III

- ▶ $M = 5$ sensors, SOI $\theta_0 = 30^\circ$, one variable and three fixed interferers:

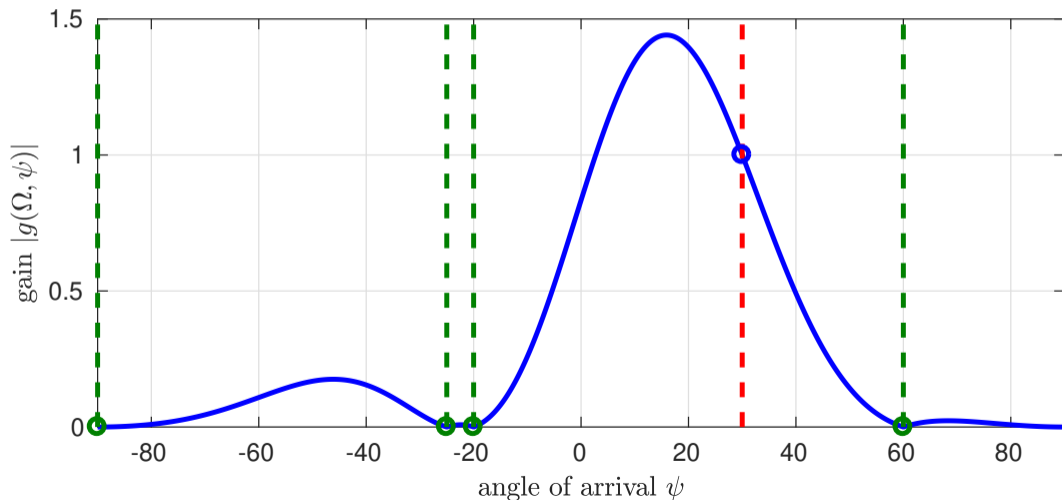

Beamforming Example — Variable Interferer III

- ▶ $M = 5$ sensors, SOI $\theta_0 = 30^\circ$, one variable and three fixed interferers:

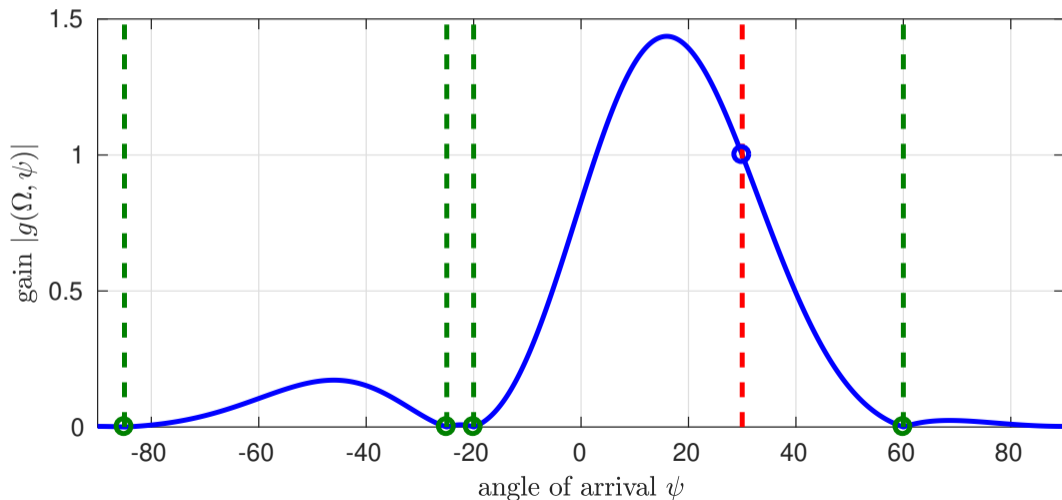

Beamforming Example — Variable Interferer III

- ▶ $M = 5$ sensors, SOI $\theta_0 = 30^\circ$, one variable and three fixed interferers:

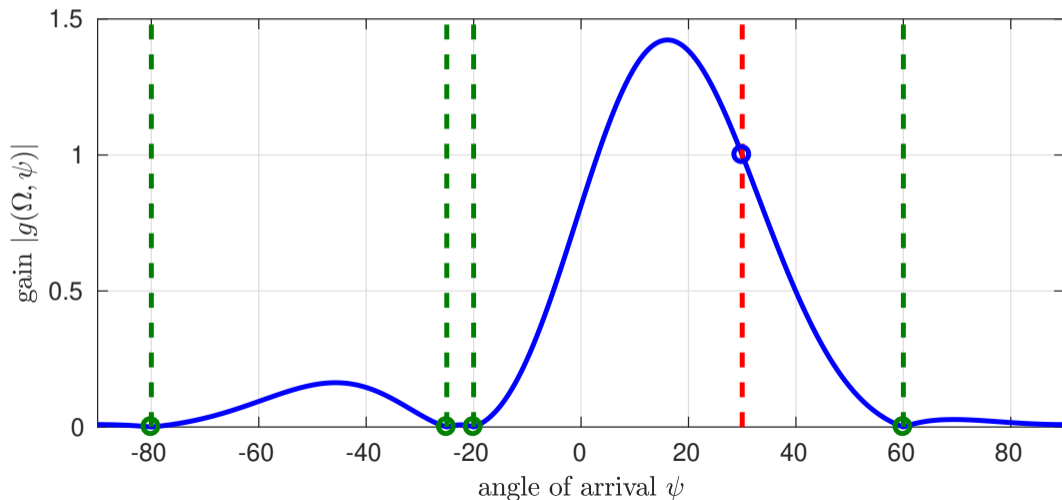

Beamforming Example — Variable Interferer III

- ▶ $M = 5$ sensors, SOI $\theta_0 = 30^\circ$, one variable and three fixed interferers:

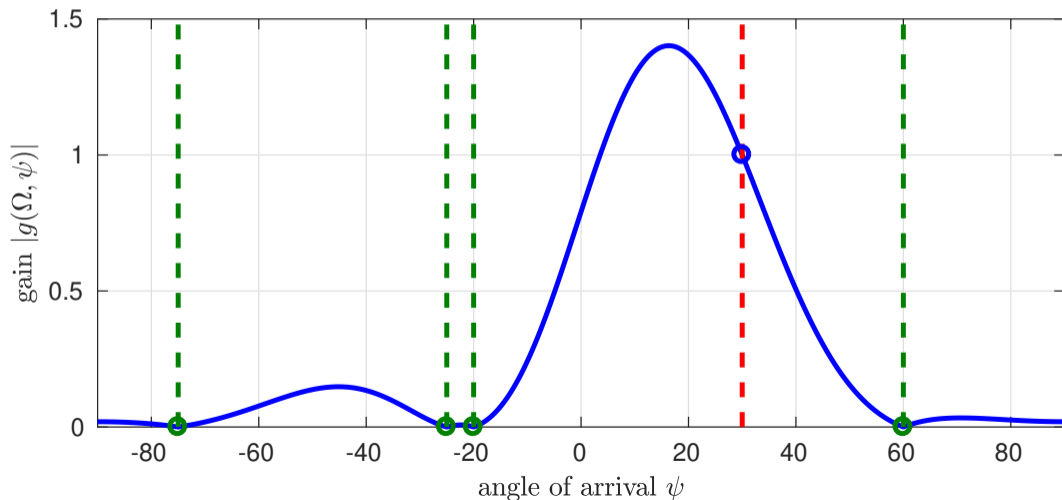

Beamforming Example — Variable Interferer III

- ▶ $M = 5$ sensors, SOI $\theta_0 = 30^\circ$, one variable and three fixed interferers:

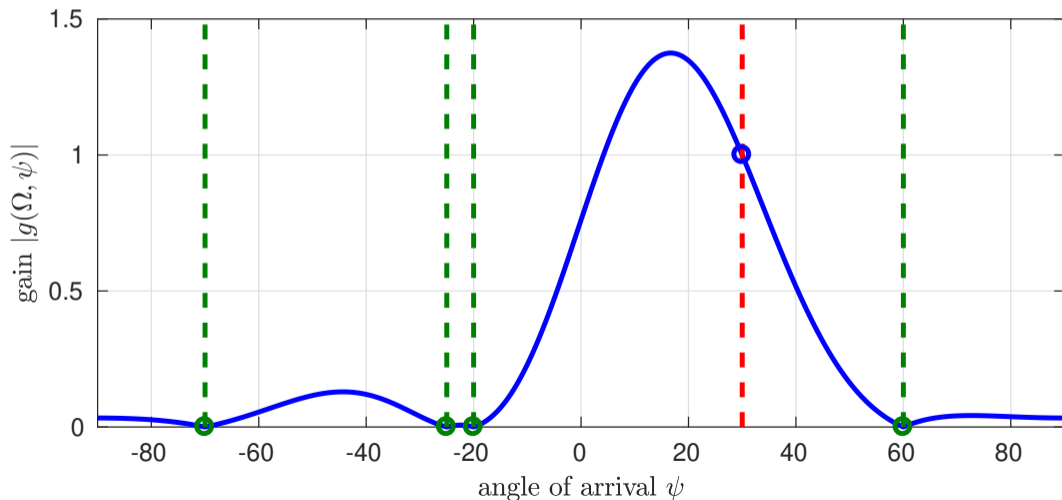

Beamforming Example — Variable Interferer III

- ▶ $M = 5$ sensors, SOI $\theta_0 = 30^\circ$, one variable and three fixed interferers:

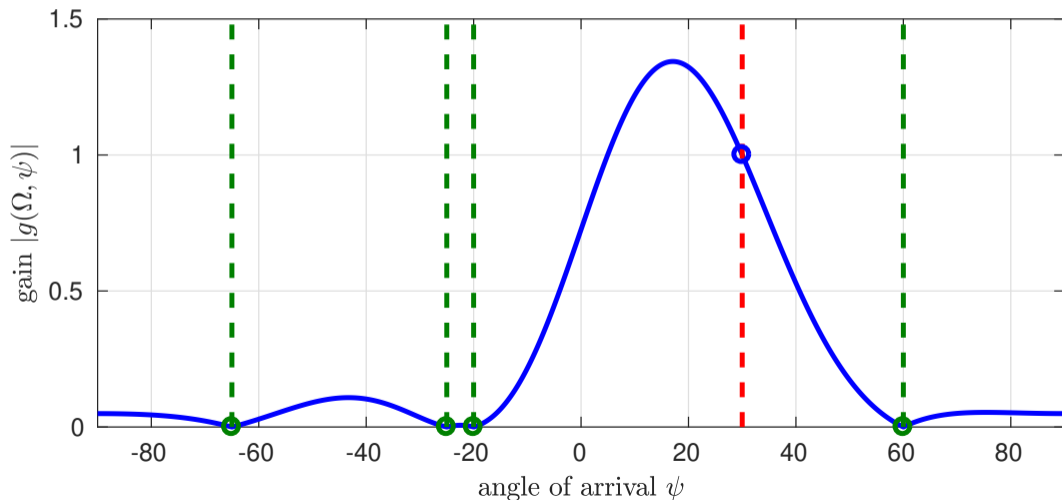

Beamforming Example — Variable Interferer III

- ▶ $M = 5$ sensors, SOI $\theta_0 = 30^\circ$, one variable and three fixed interferers:

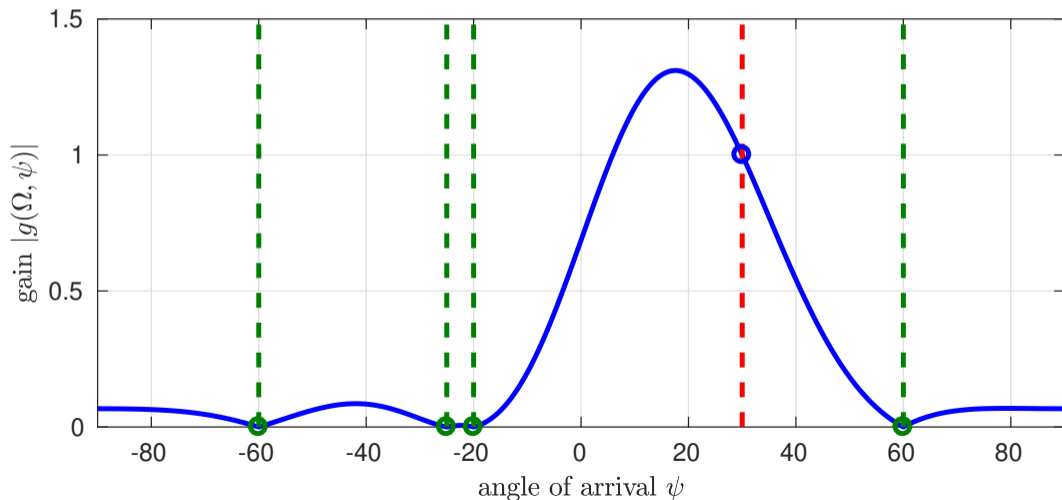

Beamforming Example — Variable Interferer III

- ▶ $M = 5$ sensors, SOI $\theta_0 = 30^\circ$, one variable and three fixed interferers:

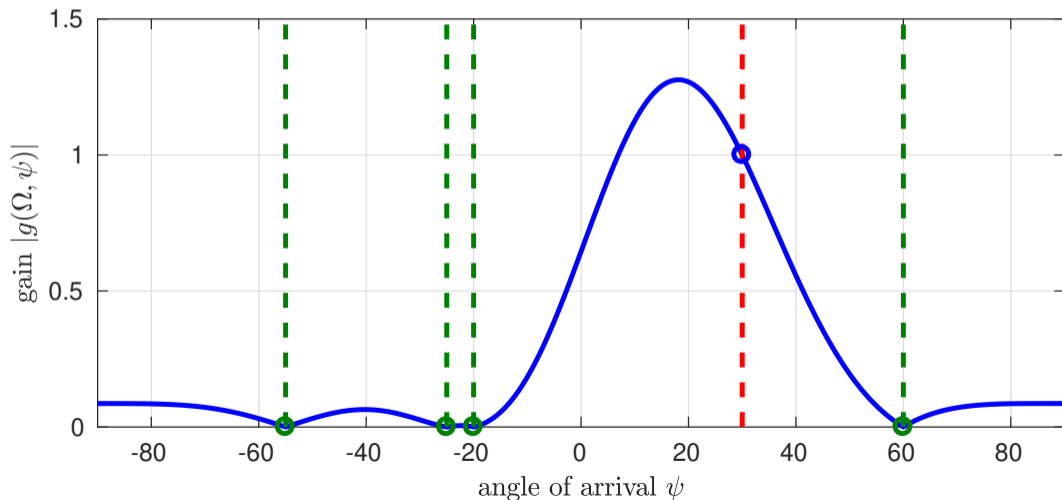

Beamforming Example — Variable Interferer III

- ▶ $M = 5$ sensors, SOI $\theta_0 = 30^\circ$, one variable and three fixed interferers:

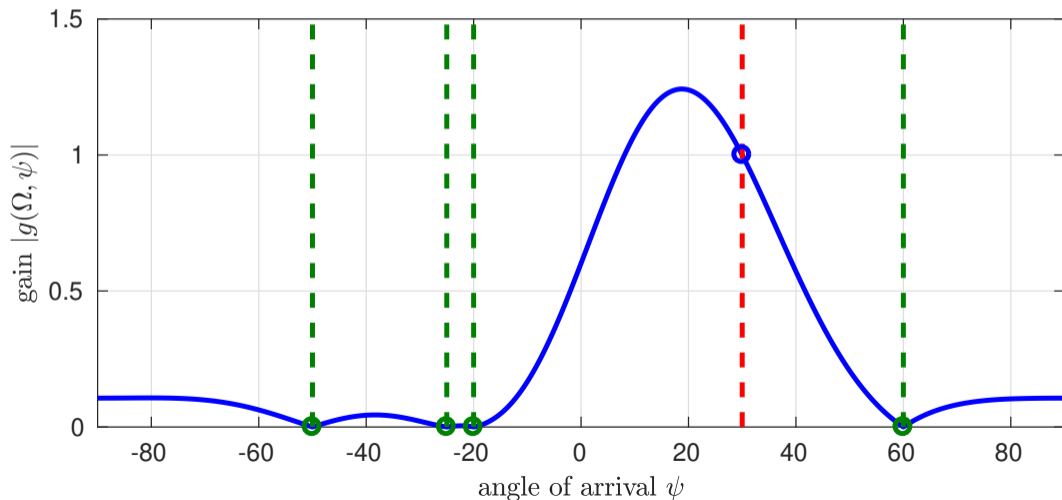

Beamforming Example — Variable Interferer III

- ▶ $M = 5$ sensors, SOI $\theta_0 = 30^\circ$, one variable and three fixed interferers:

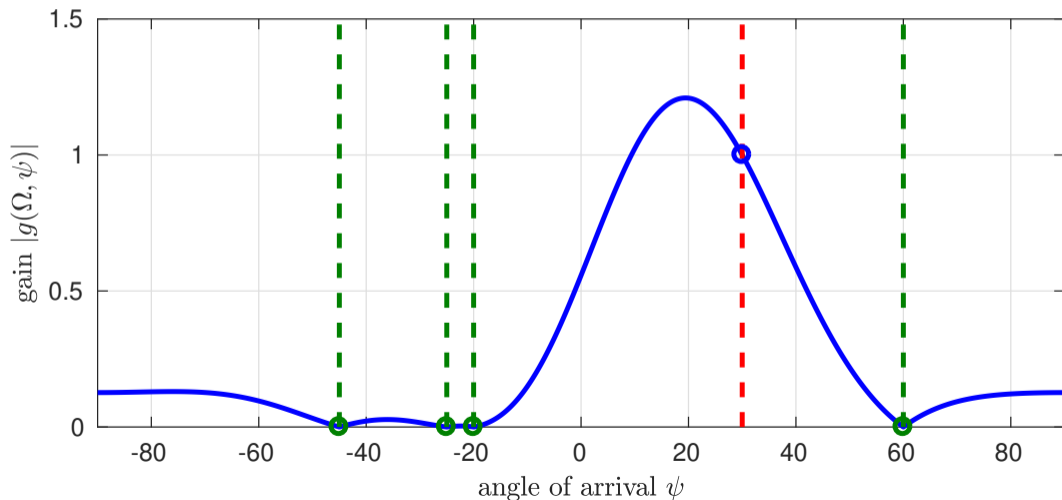

Beamforming Example — Variable Interferer III

- ▶ $M = 5$ sensors, SOI $\theta_0 = 30^\circ$, one variable and three fixed interferers:

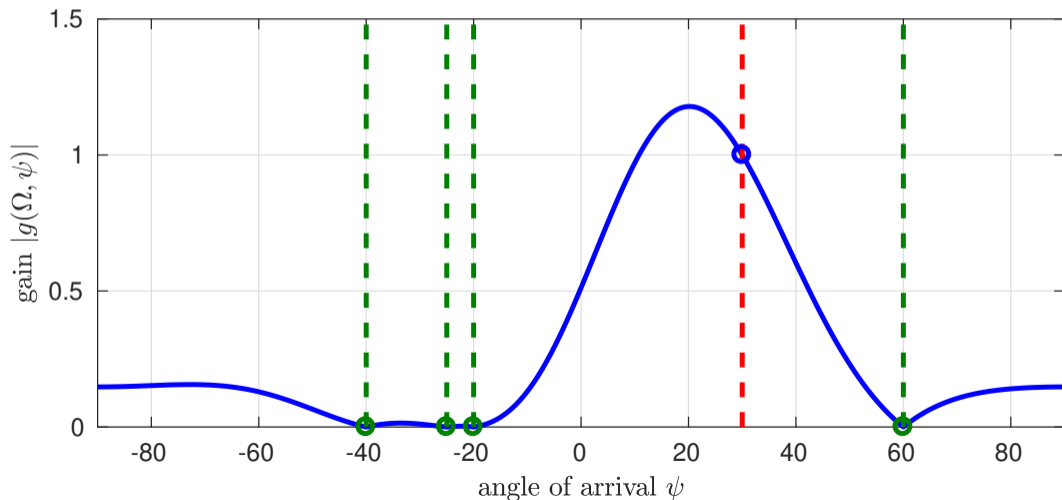

Beamforming Example — Variable Interferer III

- ▶ $M = 5$ sensors, SOI $\theta_0 = 30^\circ$, one variable and three fixed interferers:

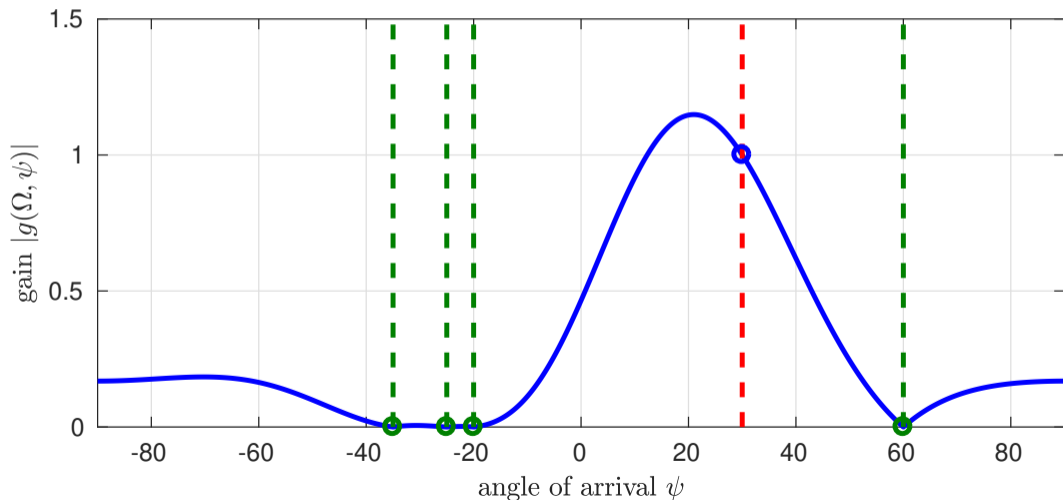

Beamforming Example — Variable Interferer III

- ▶ $M = 5$ sensors, SOI $\theta_0 = 30^\circ$, one variable and three fixed interferers:

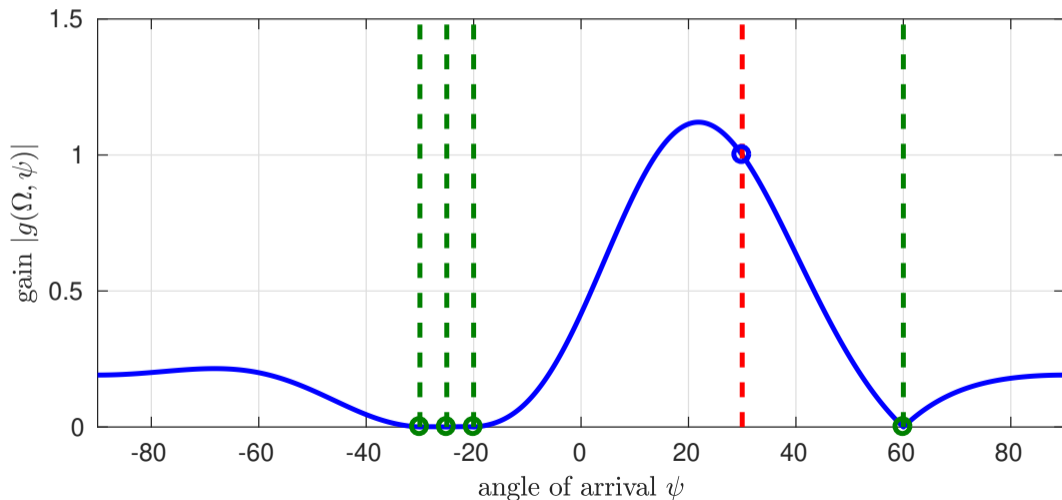

Beamforming Example — Variable Interferer III

- ▶ $M = 5$ sensors, SOI $\theta_0 = 30^\circ$, one variable and three fixed interferers:

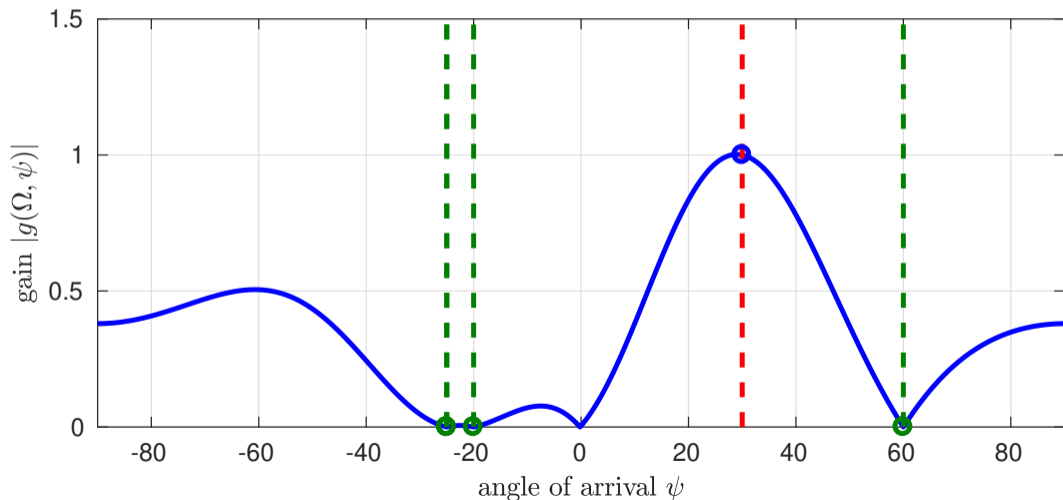

Beamforming Example — Variable Interferer III

- ▶ $M = 5$ sensors, SOI $\theta_0 = 30^\circ$, one variable and three fixed interferers:

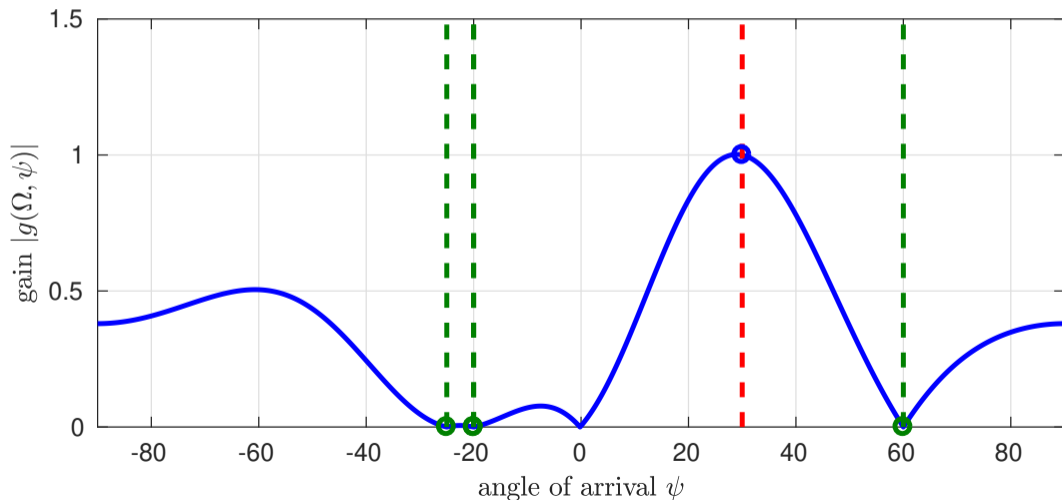

Beamforming Example — Variable Interferer III

- ▶ $M = 5$ sensors, SOI $\theta_0 = 30^\circ$, one variable and three fixed interferers:

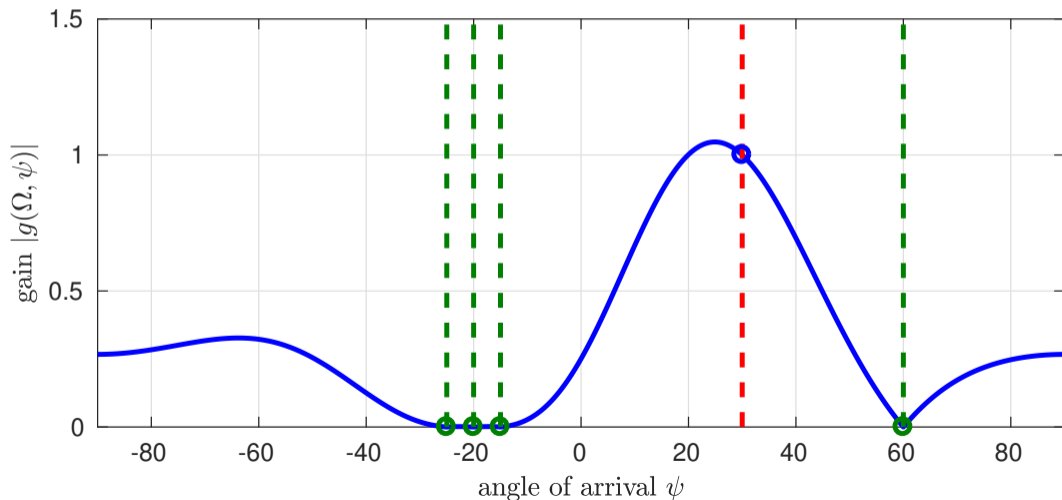

Beamforming Example — Variable Interferer III

- ▶ $M = 5$ sensors, SOI $\theta_0 = 30^\circ$, one variable and three fixed interferers:

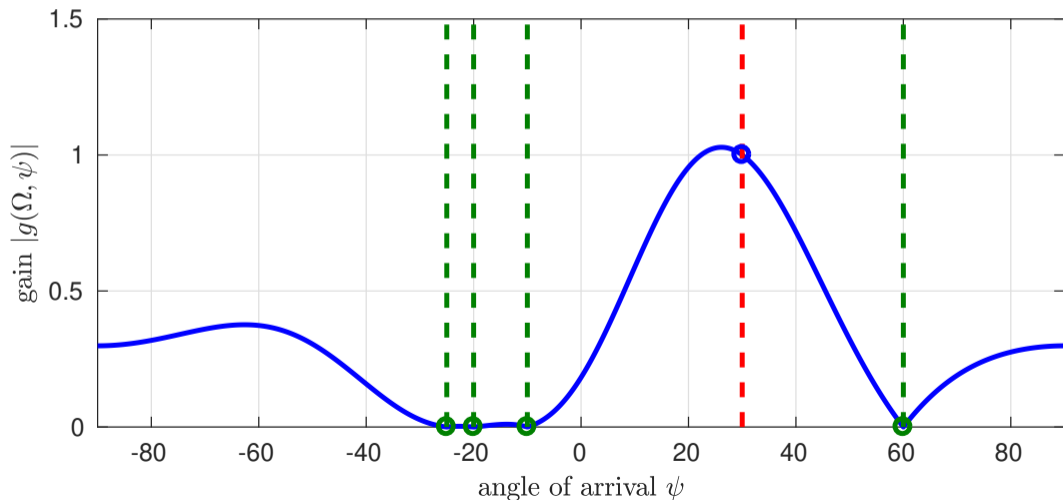

Beamforming Example — Variable Interferer III

- ▶ $M = 5$ sensors, SOI $\theta_0 = 30^\circ$, one variable and three fixed interferers:

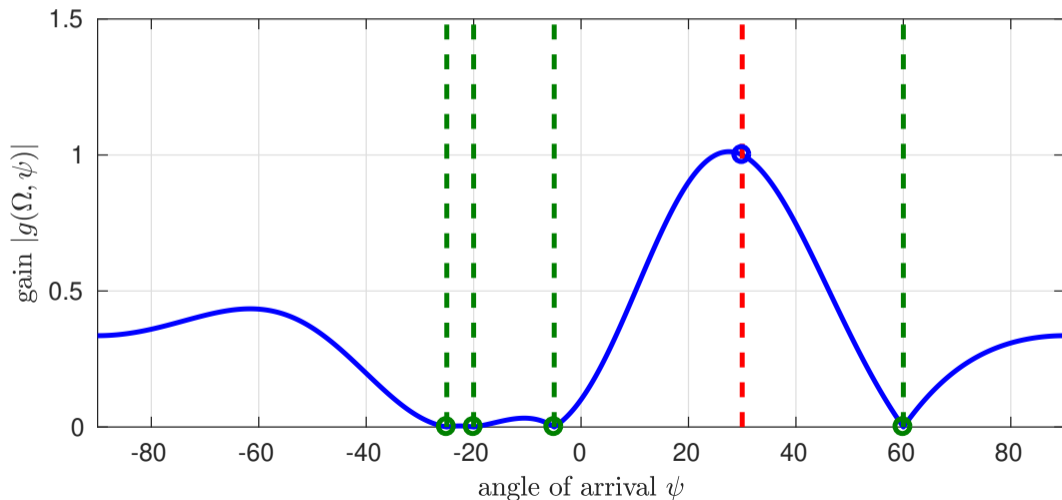

Beamforming Example — Variable Interferer III

- ▶ $M = 5$ sensors, SOI $\theta_0 = 30^\circ$, one variable and three fixed interferers:

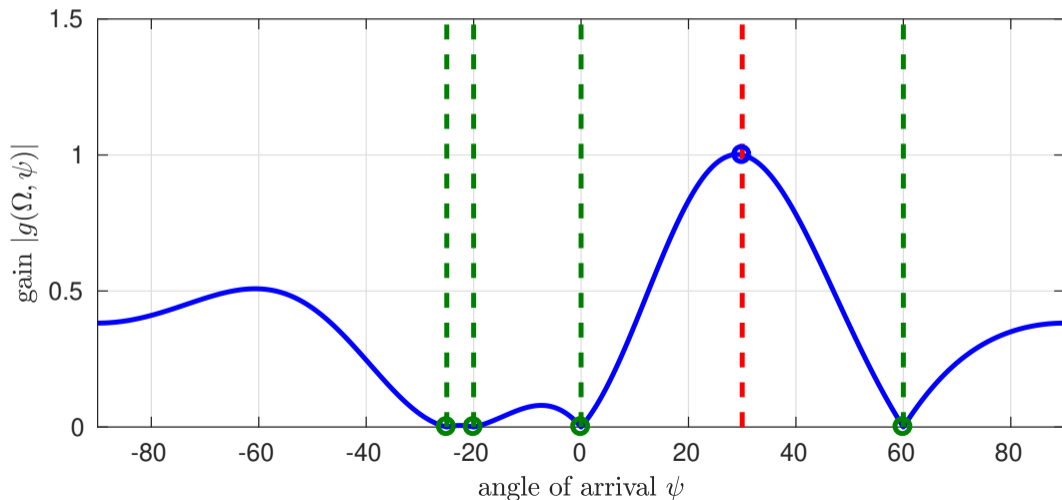

Beamforming Example — Variable Interferer III

- ▶ $M = 5$ sensors, SOI $\theta_0 = 30^\circ$, one variable and three fixed interferers:

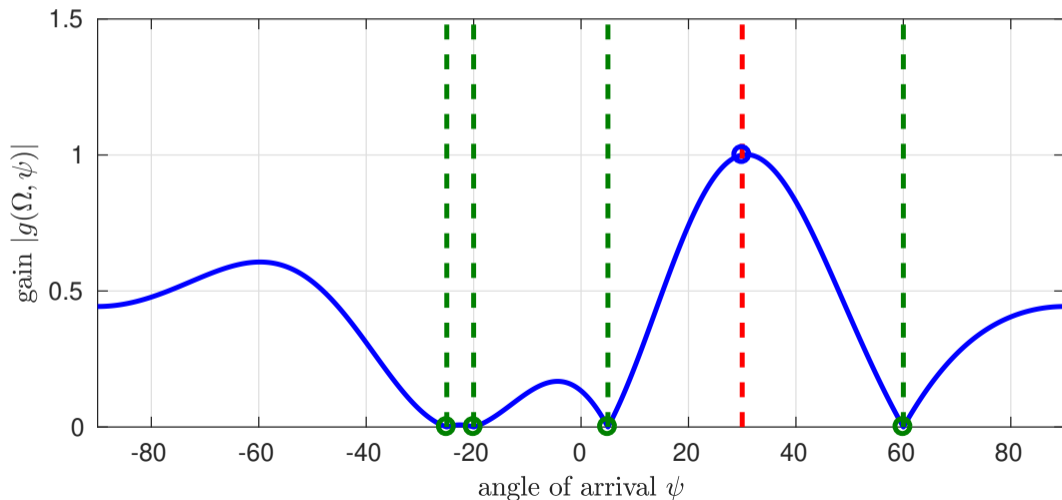

Beamforming Example — Variable Interferer III

- ▶ $M = 5$ sensors, SOI $\theta_0 = 30^\circ$, one variable and three fixed interferers:

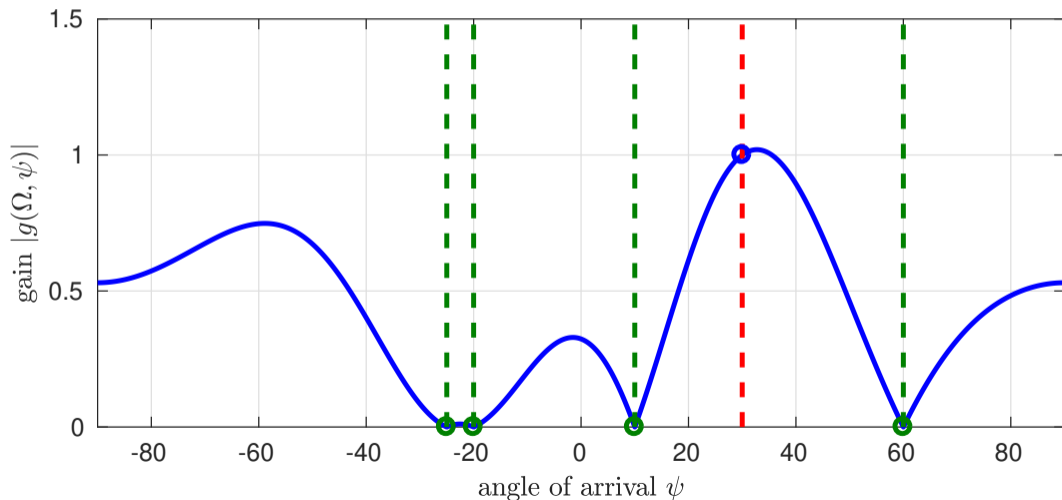

Beamforming Example — Variable Interferer III

- ▶ $M = 5$ sensors, SOI $\theta_0 = 30^\circ$, one variable and three fixed interferers:

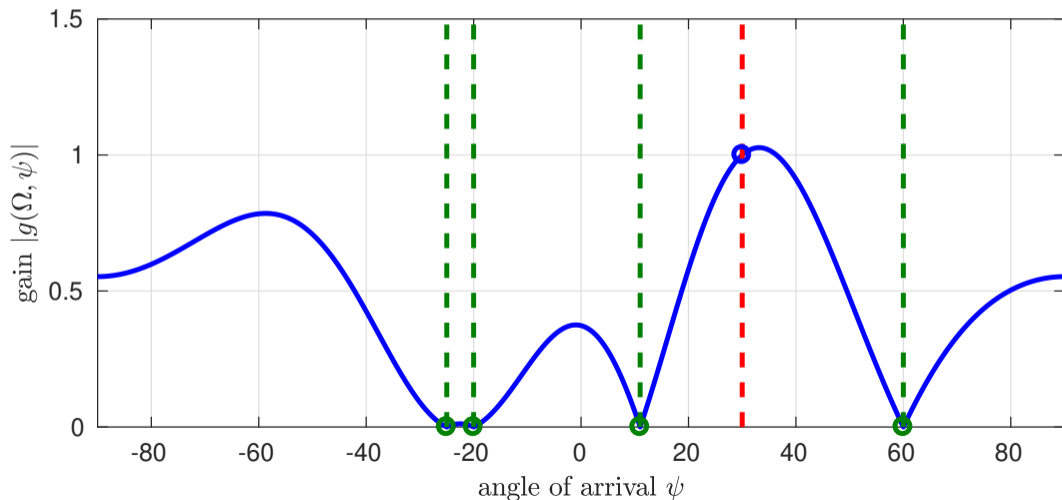

Beamforming Example — Variable Interferer III

- ▶ $M = 5$ sensors, SOI $\theta_0 = 30^\circ$, one variable and three fixed interferers:

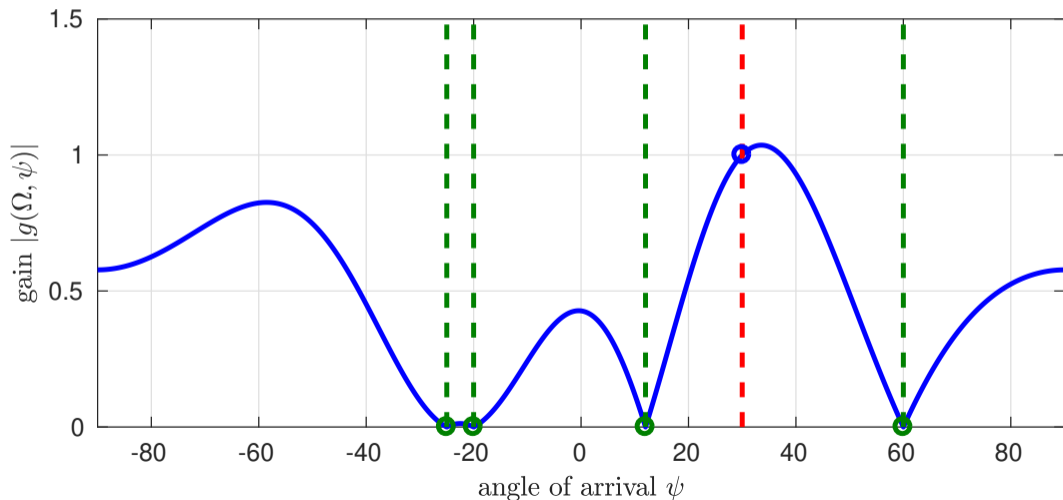

Beamforming Example — Variable Interferer III

- ▶ $M = 5$ sensors, SOI $\theta_0 = 30^\circ$, one variable and three fixed interferers:

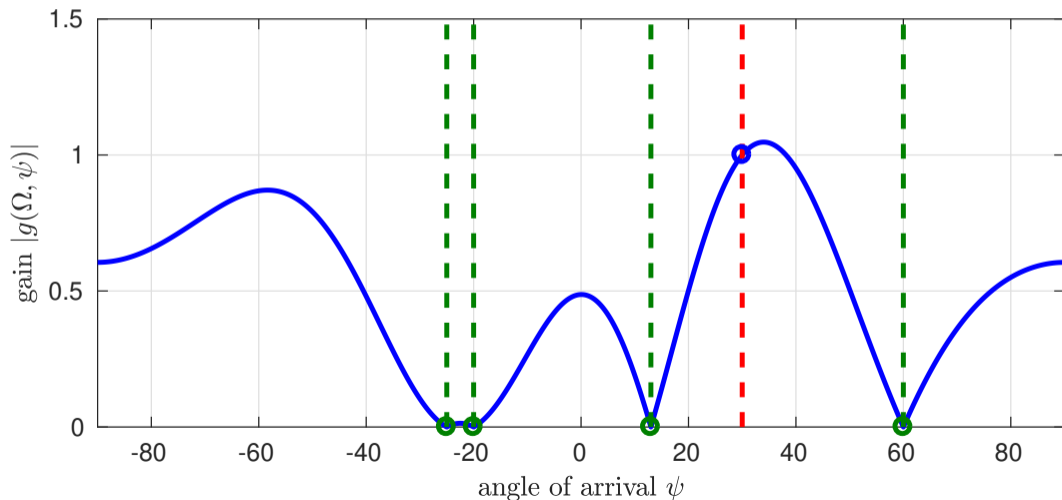

Beamforming Example — Variable Interferer III

- ▶ $M = 5$ sensors, SOI $\theta_0 = 30^\circ$, one variable and three fixed interferers:

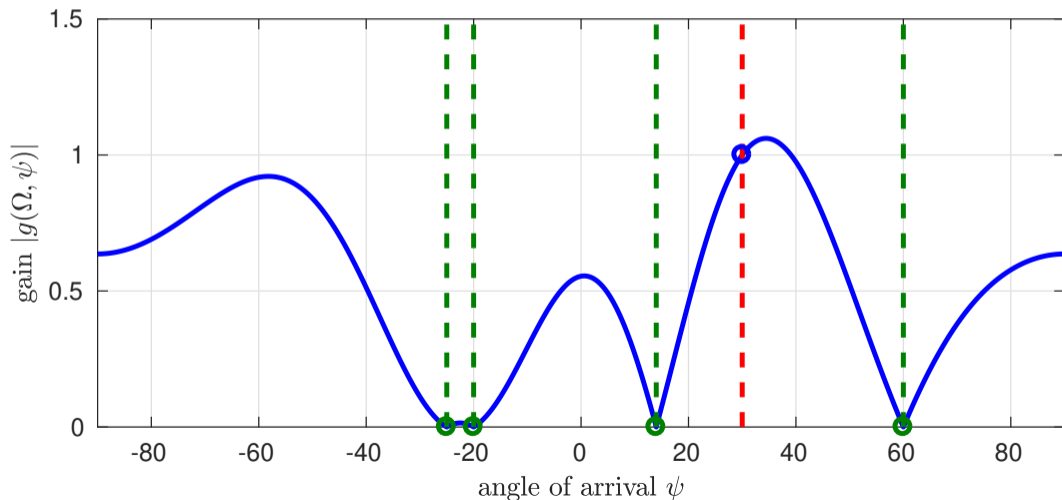

Beamforming Example — Variable Interferer III

- ▶ $M = 5$ sensors, SOI $\theta_0 = 30^\circ$, one variable and three fixed interferers:

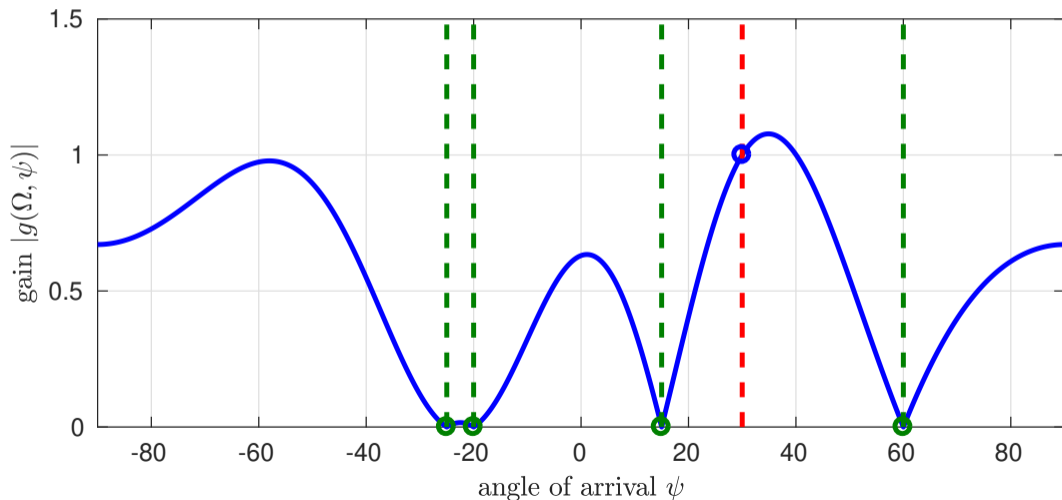

Beamforming Example — Variable Interferer III

- ▶ $M = 5$ sensors, SOI $\theta_0 = 30^\circ$, one variable and three fixed interferers:

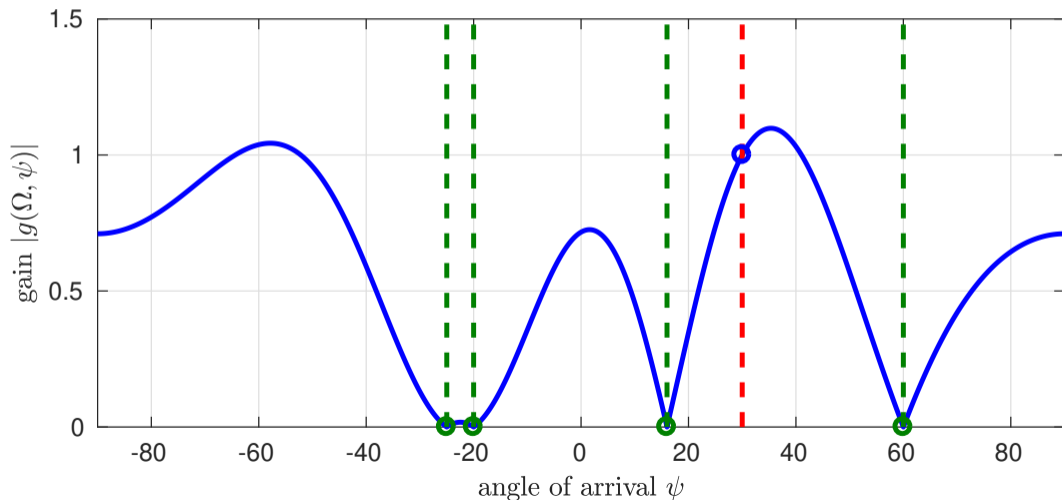

Beamforming Example — Variable Interferer III

- ▶ $M = 5$ sensors, SOI $\theta_0 = 30^\circ$, one variable and three fixed interferers:

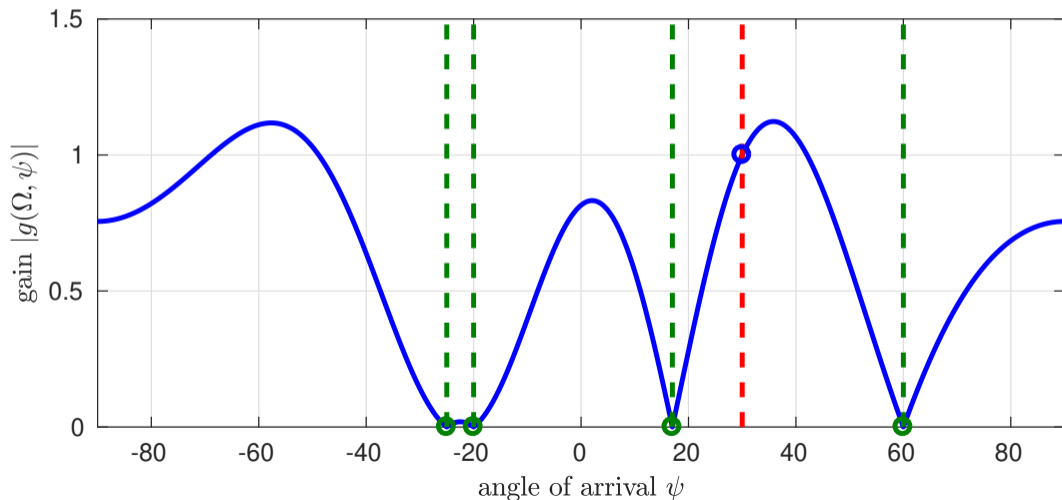

Beamforming Example — Variable Interferer III

- ▶ $M = 5$ sensors, SOI $\theta_0 = 30^\circ$, one variable and three fixed interferers:

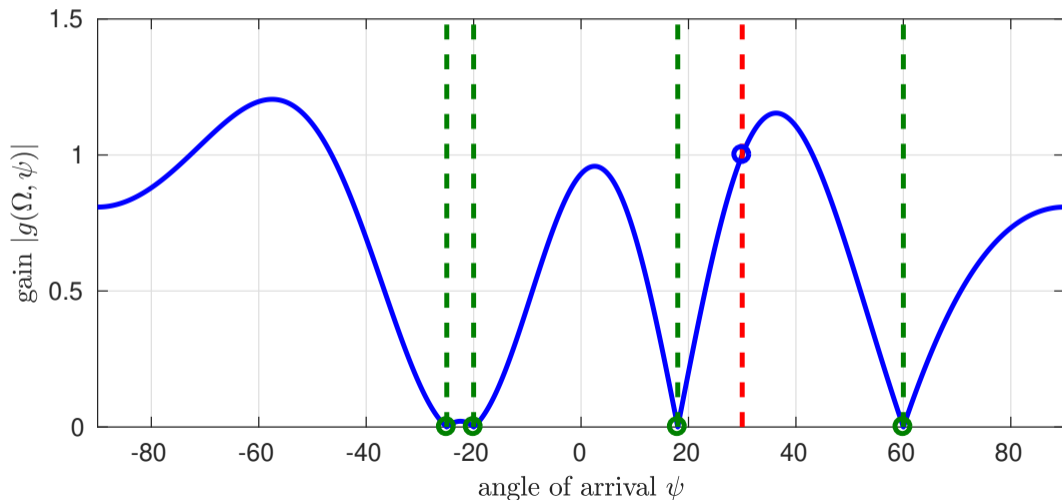

Beamforming Example — Variable Interferer III

- ▶ $M = 5$ sensors, SOI $\theta_0 = 30^\circ$, one variable and three fixed interferers:

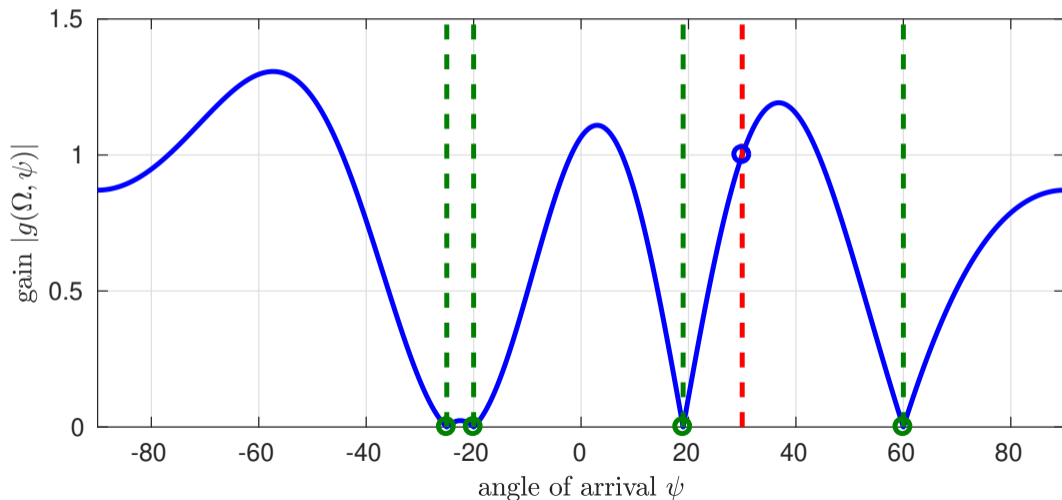

Beamforming Example — Variable Interferer III

- ▶ $M = 5$ sensors, SOI $\theta_0 = 30^\circ$, one variable and three fixed interferers:

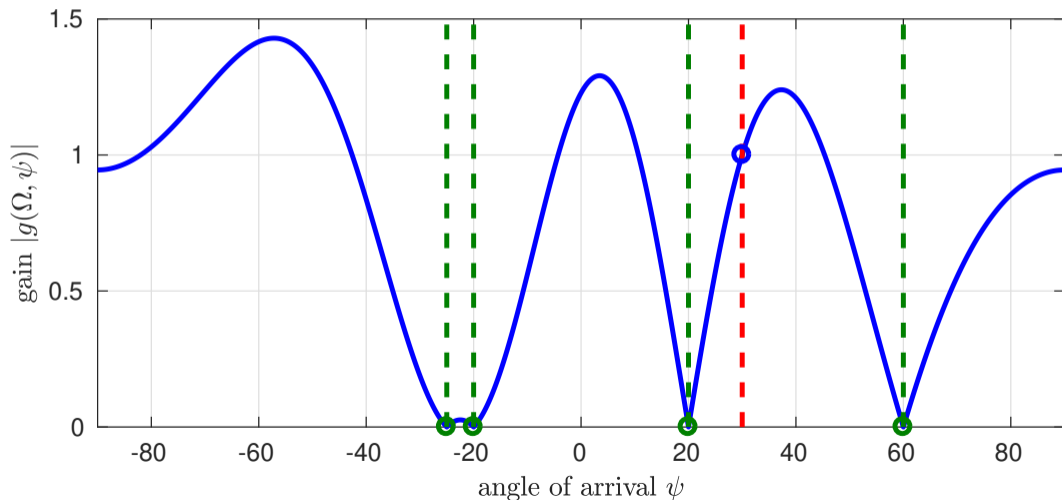

Beamforming Example — Variable Interferer III

- ▶ $M = 5$ sensors, SOI $\theta_0 = 30^\circ$, one variable and three fixed interferers:

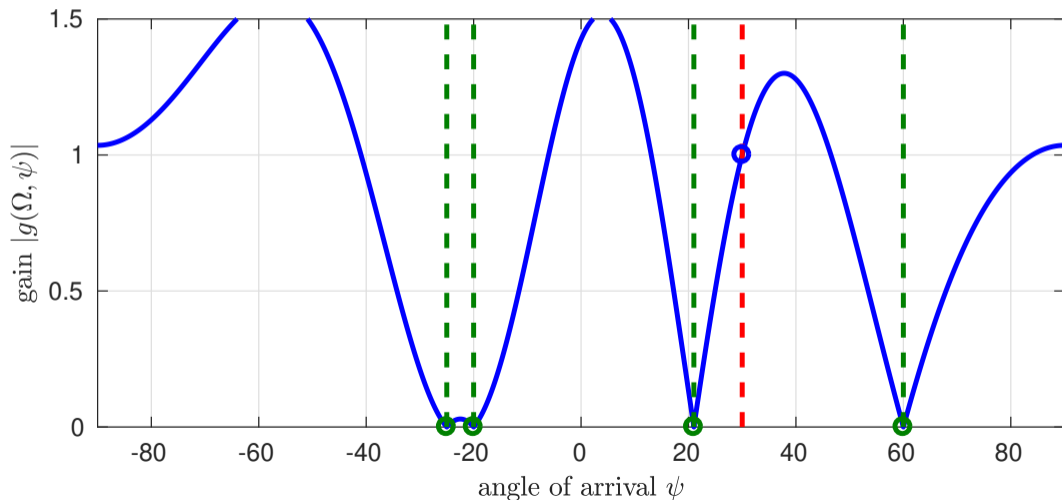

Beamforming Example — Variable Interferer III

- ▶ $M = 5$ sensors, SOI $\theta_0 = 30^\circ$, one variable and three fixed interferers:

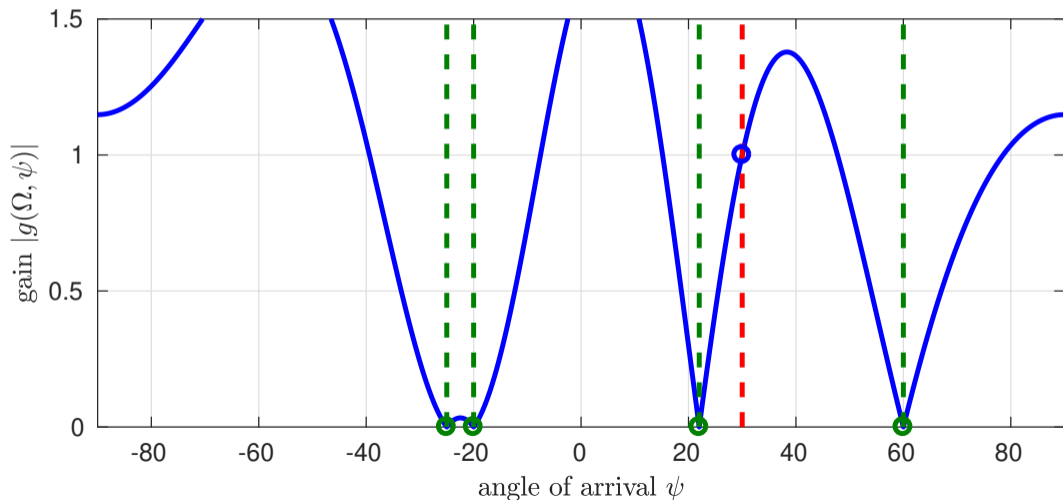

Beamforming Example — Variable Interferer III

- ▶ $M = 5$ sensors, SOI $\theta_0 = 30^\circ$, one variable and three fixed interferers:

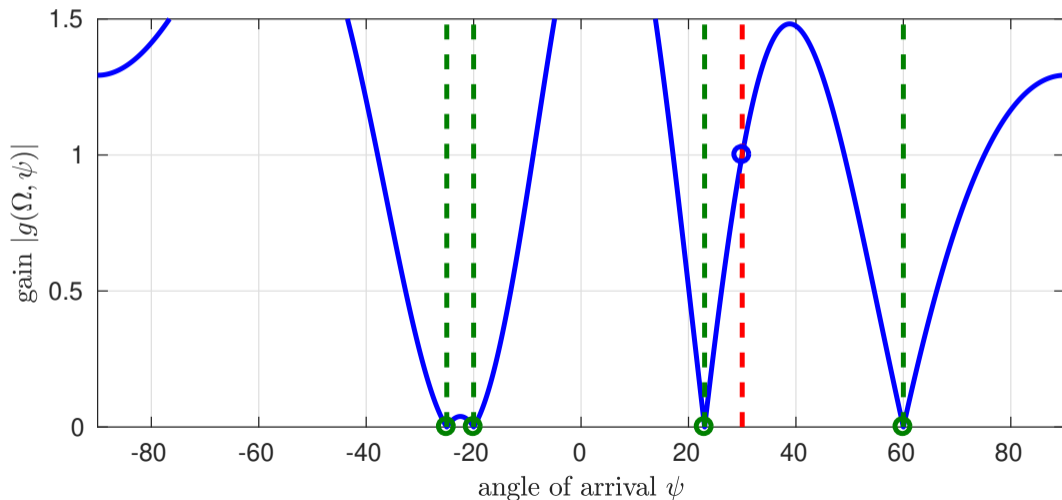

Beamforming Example — Variable Interferer III

- ▶ $M = 5$ sensors, SOI $\theta_0 = 30^\circ$, one variable and three fixed interferers:

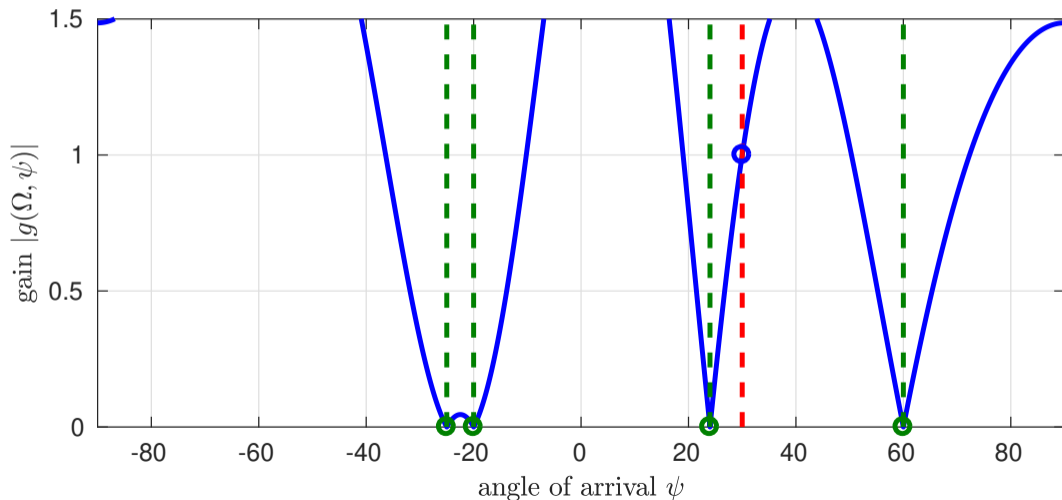

Beamforming Example — Variable Interferer III

- ▶ $M = 5$ sensors, SOI $\theta_0 = 30^\circ$, one variable and three fixed interferers:

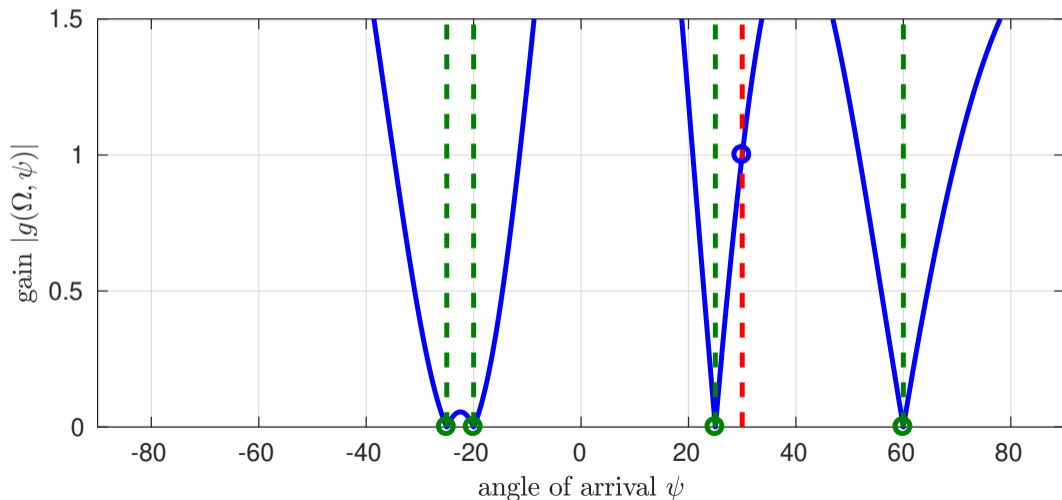

Data Independent Beamforming



- ▶ Previous beamformer designs were based on the knowledge of DoA of the signal of interest and of interfering sources;
- ▶ remaining degrees of freedom are invested to suppress spatially white noise;
- ▶ using the analogy between spatial and temporal processing, classical filter design techniques can be invoked to design arrays with a bandpass-type angular response;
- ▶ beamformers based on source parameters (frequency, DoA) rather the actual received waveforms are termed **data independent beamformers**;
- ▶ this is in contrast to **statistically optimum beamformers**, which take the received signal statistics into account.

1.8 Statistically Optimum Beamforming

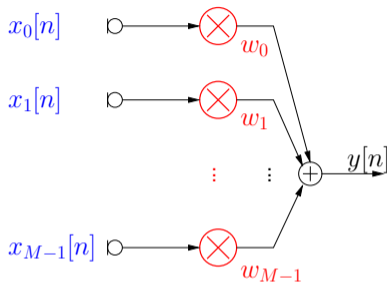

- ▶ Statistically optimum beamformer minimise e.g. the signal power of the beamformer output, $y[n]$;
- ▶ to avoid the trivial solution $\mathbf{w} = \mathbf{0}$, the signal of interest needs to be protected by constraints;

- ▶ this results in e.g. the following constrained optimisation problem

$$\min_{\mathbf{w}^*} \mathcal{E}\{|y[n]|^2\} \quad \text{subject to} \quad \mathbf{s}_{\Omega, \vartheta}^H \mathbf{w} = 1$$

- ▶ the solution to this specific statistically optimum beamformer is known as the **minimum variance distortionless response** (MVDR).

MVDR Beamformer

- ▶ Solving the MVDR problem: minimise the power of $y[n] = \mathbf{w}^H \mathbf{x}$ subject to the constraint $\mathbf{w}^H \mathbf{s}_{\Omega_0, \vartheta_0} = 1$;
- ▶ Formulation using a Lagrange multiplier λ :

$$\frac{\partial}{\partial \mathbf{w}^*} \left(\mathbf{w}^H \mathcal{E} \{ \mathbf{x} \mathbf{x}^H \} \mathbf{w} - \lambda (\mathbf{w}^H \mathbf{s}_{\Omega_0, \vartheta_0} - 1) \right) = \mathbf{R}_{xx} \mathbf{w} - \lambda \mathbf{s}_{\Omega_0, \vartheta_0} = \mathbf{0}$$

- ▶ the solution $\mathbf{w} = \lambda \mathbf{R}_{xx}^{-1} \mathbf{s}_{\Omega_0, \vartheta_0}$ is inserted into the constraint equation to determine λ :

$$\lambda \mathbf{s}_{\Omega_0, \vartheta_0}^H \mathbf{R}_{xx}^{-1} \mathbf{s}_{\Omega_0, \vartheta_0} = 1$$

- ▶ therefore

$$\mathbf{w}_{\text{MVDR}} = \left(\mathbf{s}_{\Omega_0, \vartheta_0}^H \mathbf{R}_{xx}^{-1} \mathbf{s}_{\Omega_0, \vartheta_0} \right)^{-1} \mathbf{R}_{xx}^{-1} \mathbf{s}_{\Omega_0, \vartheta_0}$$

- ▶ this stastically optimum beamformer has various other names, e.g. Capon beamformer.

MVDR Beamformer — Simple Case



- ▶ In the case of spatially white noise input, such that

$$\mathbf{R}_{xx} = \sigma_{xx}^2 \mathbf{I} \quad \longrightarrow \quad \mathbf{R}_{xx}^{-1} = \sigma_{xx}^{-2} \mathbf{I}$$

the MVDR solution reduces to

$$\mathbf{w}_{\text{MVDR}} = \frac{\mathbf{s}_{\Omega_0, \vartheta_0}}{\|\mathbf{s}_{\Omega_0, \vartheta_0}\|_2^2} = \frac{\mathbf{s}_{\Omega_0, \vartheta_0}}{M} \quad ;$$

- ▶ this is identical to the data independent beamformer in the absence of interference (i.e. no spatially structured noise);

Generalised Sidelobe Canceller (GSC)

- ▶ The generalised sidelobe canceller is a specific implementation of the MVDR beamformer; it transforms the constrained MVDR problem into an **unconstrained optimisation problem**;
- ▶ a first guess at the solution is performed by the **quiescent beamformer** \mathbf{w}_q , which is identical to the previously defined data independent beamformer, obtained by inverting the constraint equation

$$\mathbf{C}^H \mathbf{w}_q = \mathbf{f} \quad \longrightarrow \quad \mathbf{w}_q = (\mathbf{C}^H)^\dagger \mathbf{f}$$

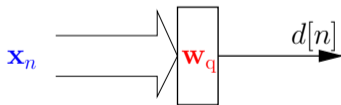

- ▶ the quiescent beamformer eliminates interferers captured by \mathbf{C} and \mathbf{f} , but passes the signal of interest, any interferers unaccounted for in the constraints, and spatially distributed noise.

- ▶ GSE idea: produce array signals that are free of any contribution from the signal of interest, and use the resulting signal vector $\mathbf{u}[n]$ to eliminate remaining interference from the quiescent output:

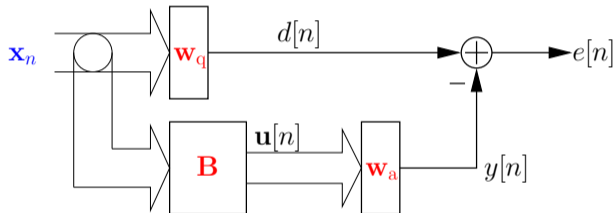

- ▶ the blocking matrix \mathbf{B} eliminates the signal of interest and any interferers captured by the constraints;
- ▶ the vector \mathbf{w}_a will be based on the statistics of $\mathbf{u}[n]$ and $d[n]$ to minimise the beamformer output variance $\mathcal{E}\{|e[n]|^2\}$.

GSC — Blocking Matrix

- ▶ In order to project away from the constraints,

$$\mathbf{B} \cdot \mathbf{C} = \mathbf{B} \cdot \left[\mathbf{s}_{\Omega_0, \vartheta_0} \quad \mathbf{s}_{\Omega_1, \vartheta_1} \quad \dots \quad \mathbf{s}_{\Omega_{r-1}, \vartheta_{r-1}} \right] = \mathbf{0}$$

- ▶ assuming that the r constraints are linearly independent, the singular value decomposition of the constraint matrix yields

$$\mathbf{B} \cdot \left[\mathbf{U}_0 \quad \mathbf{U}_0^\perp \right] \left[\begin{array}{c|c} \sigma_0 & \mathbf{0} \\ \vdots & \mathbf{0} \\ \hline \mathbf{0} & \mathbf{0} \end{array} \right] \cdot \mathbf{V}^H = \mathbf{0}$$

- ▶ the matrix $\mathbf{U}_0^\perp \in \mathbb{C}^{M \times (M-r)}$ spans the nullspace of \mathbf{C}^H , and

$$\mathbf{B} = (\mathbf{U}_0^\perp)^H \in \mathbb{C}^{(M-r) \times M}$$

has the required property, as $(\mathbf{U}_0^\perp)^H \cdot \left[\mathbf{U}_0 \quad \mathbf{U}_0^\perp \right] \boldsymbol{\Sigma} = \left[\mathbf{0} \quad \mathbf{I} \right] \cdot \boldsymbol{\Sigma} = \mathbf{0}$.

GSC — Unconstrained Optimisation

- ▶ The beamforming vector \mathbf{w}_a is adjusted to minimise the output power;
- ▶ the MMSE or Wiener solution is given by

$$\mathbf{w}_a = \mathbf{R}_{uu}^{-1} \cdot \mathbf{p} = \frac{\mathbf{B}\mathbf{R}_{xx}(\mathbf{C}^H)^\dagger \mathbf{f}}{\mathbf{B}\mathbf{R}_{xx}\mathbf{B}^H}$$

with the covariance matrix

$$\mathbf{R}_{uu} = \mathcal{E}\{\mathbf{u}[n] \cdot \mathbf{u}^H[n]\} = \mathbf{B} \mathcal{E}\{\mathbf{x}[n] \cdot \mathbf{x}^H[n]\} \mathbf{B}^H = \mathbf{B}\mathbf{R}_{xx}\mathbf{B}^H$$

and the cross-correlation vector

$$\mathbf{p} = \mathcal{E}\{\mathbf{u}[n] \cdot d^*[n]\} = \mathbf{B}\mathbf{R}_{xx}\mathbf{w}_q$$

- ▶ iterative optimisation schemes, such as the least mean squares (LMS) algorithm may be used to approximate the MMSE solution.

1.9 Beamforming and MIMO Processing

- ▶ Assume a transmission scenario with an M -element transmit (Tx) antenna array and an N -element receive (Rx) array;

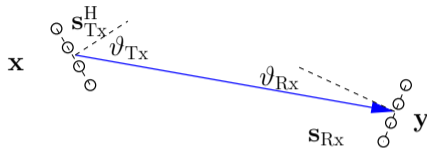

- ▶ in the absence of scatterers and any attenuation, the farfield transmission from the transmit antenna is characterised by a steering vector \mathbf{s}_{Tx}^H ;
- ▶ the incoming waveform at the Rx device is described by another steering vector \mathbf{s}_{Rx} ;
- ▶ the overall MIMO system between a Tx vector $\mathbf{x} \in \mathbb{C}^M$ and an Rx vector $\mathbf{y} \in \mathbb{C}^N$ is described as

$$\mathbf{y} = \mathbf{s}_{Rx} \cdot \mathbf{s}_{Tx}^H \cdot \mathbf{x} = \mathbf{H}\mathbf{x}$$

- ▶ the MIMO system matrix $\mathbf{H} = \mathbf{s}_{Rx} \cdot \mathbf{s}_{Tx}^H$ is rank one only.

- ▶ The farfield assumption is convenient for beamforming, but leads to a rank one MIMO system matrix which is incompatible with the desire to extract multiple independent subchannels or with to achieve diversity;
- ▶ **rich scattering** in connection with MIMO usually implies multiple reflections of signals;
- ▶ together with a sufficiently **large antenna spacing** means that the farfield assumption is invalid and the MIMO system matrix is **not rank deficient**;
- ▶ some suggestions of “sufficiently large spacing” imply an antenna element distance of $d > 10\lambda$;
- ▶ recall spatial sampling requires $d < \frac{1}{2}\lambda$!

Beamforming with Spatial Aliasing

- ▶ For a flexible spatial sampling with $d = \alpha\lambda$, $0 < \alpha \in \mathbb{R}$, the steering vector for a waveform with normalised angular frequency Ω and DoA ϑ is

$$\mathbf{y} = e^{j\Omega n} \begin{bmatrix} 1 \\ e^{j2\alpha\Omega \sin(\vartheta)} \\ \vdots \\ e^{j2\alpha(M-1)\Omega \sin(\vartheta)} \end{bmatrix} = \mathbf{s}_{2\alpha\Omega, \vartheta} \cdot e^{j\Omega}$$

- ▶ inspecting $\mathbf{s}_{2\alpha\Omega, \vartheta}$ the steering vector is aliased to a different frequency $2\alpha\Omega$;
- ▶ although the correct frequency can be retrieved unambiguously from temporal sampling of any array element, at Ω various different angles could provide the same steering vector $\mathbf{s}_{2\alpha\Omega, \vartheta}$;
- ▶ the array performs **spatial undersampling**, resulting in **spatial aliasing**.

Spatial Undersampling Example

- ▶ Beamforming parameters: signal of interest with $\Omega = \frac{\pi}{2}$, direction of arrival $\vartheta = 30^\circ$, $M = 32$ array elements;
- ▶ data independent beamformer design with **correct spatial sampling** ($d = \lambda/2$) and **incorrect spatial sampling** ($d = 10\lambda$):

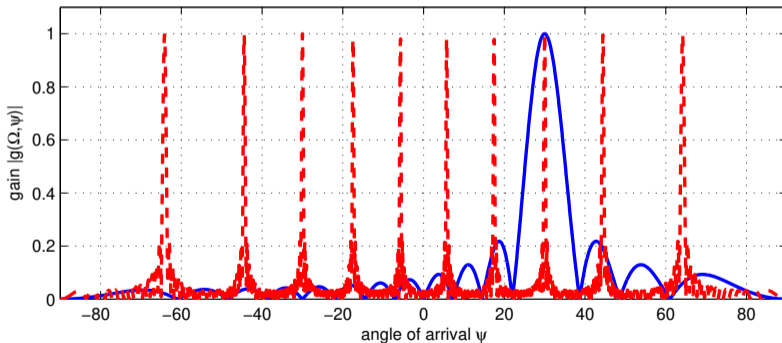

- ▶ MIMO systems perform beamforming, but may dissipate energy into aliased directions.

1.10 Broadband MVDR Beamformer

- ▶ Each sensor is followed by a tap delay line of dimension L , giving a total of ML coefficients in a vector $\mathbf{v} \in \mathbb{C}^{ML}$

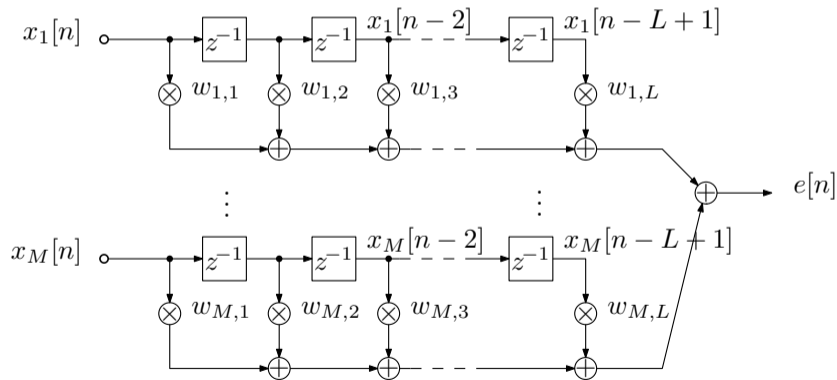

Broadband MVDR Beamformer Constraints



- ▶ A larger input vector $\mathbf{x}_n \in \mathbb{C}^{ML}$ is generated, also including lags;
- ▶ the general approach is similar to the narrowband system, minimising the power of $e[n] = \mathbf{v}^H \mathbf{x}_n$;
- ▶ however, we require several constraint equations to protect the signal of interest, e.g.

$$\mathbf{C} = [\mathbf{s}(\vartheta_s, \Omega_0), \mathbf{s}(\vartheta_s, \Omega_1) \dots \mathbf{s}(\vartheta_s, \Omega_{L-1})] \quad (1)$$

- ▶ these L constraints pin down the response to unit gain at L separate points in frequency:

$$\mathbf{C}^H \mathbf{v} = \mathbf{1} ; \quad (2)$$

- ▶ generally $\mathbf{C} \in \mathbb{C}^{ML \times L}$, but simplifications can be applied if the look direction is towards broadside.

Broadband Generalised Sidelobe Canceller

- ▶ A quiescent beamformer $\mathbf{v}_q = (\mathbf{C}^H)^{\dagger} \mathbf{1} \in \mathbb{C}^{ML}$ picks the signal of interest;
- ▶ the quiescent beamformer is optimal for AWGN but generally passes structured interference;
- ▶ the output of the blocking matrix \mathbf{B} contains interference only, which requires $[\mathbf{B}\mathbf{C}]$ to be unitary; hence $\mathbf{B} \in \mathbb{C}^{ML \times (M-1)L}$;
- ▶ an adaptive noise canceller $\mathbf{v}_a \in \mathbb{C}^{(M-1)L}$ aims to remove the residual interference:

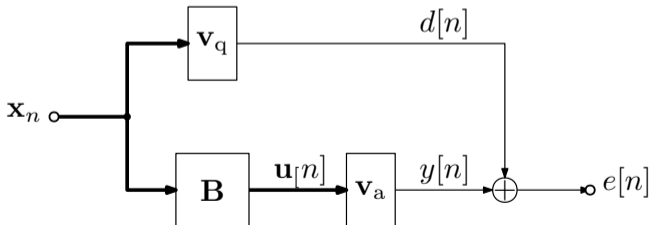

- ▶ note: all dimensions are determined by $\{M, L\}$.

Broadband Beamformer Example

- ▶ We assume a **signal of interest** from $\vartheta = 30^\circ$;
- ▶ three **interferers** with angles $\vartheta_i \in \{-40^\circ, -10^\circ, 80^\circ\}$ active over the frequency range $\Omega = 2\pi \cdot [0.1; 0.45]$ at signal to interference ratio of -40 dB;

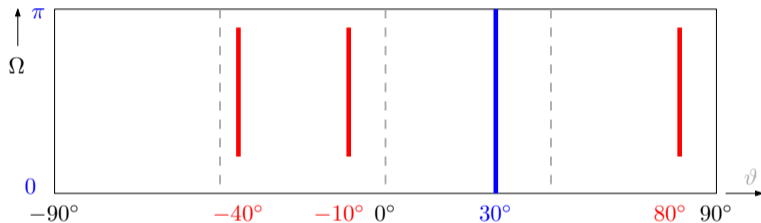

- ▶ $M = 8$ element linear uniform array is also corrupted by spatially and temporally white additive Gaussian noise at 20 dB SNR;
- ▶ tap-delay-line length: $L = 150$;
- ▶ cost per iteration: approx. 2 MMACs (standard), can be reduced to 10 kMACs when efficiently implemented.

Broadband Quiescent Beamformer

- ▶ Directivity pattern of quiescent standard broadband beamformer:

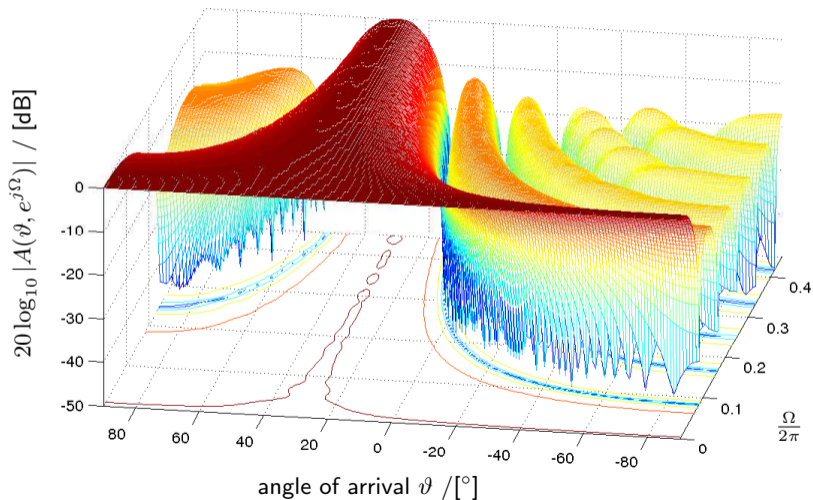

Optimised Broadband Beamformer

- Directivity pattern of the broadband beamformer:

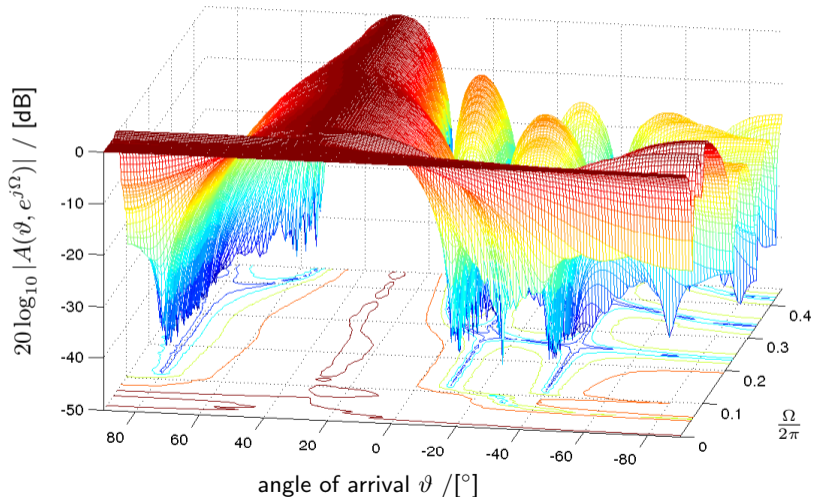

1.11 Summary



- ▶ Spatial sampling by an array of sensors (e.g. antenna elements) has been explored;
- ▶ the spatial data window of a narrowband source is characterised by the steering vector;
- ▶ appropriate data independent beamformers can be designed based on the steering vectors of desired sources and interferers;
- ▶ statistically optimum beamformers are based on the signal statistics;
- ▶ a specific statistically optimum beamformer, the generalised sidelobe canceller, has been reviewed — it uses signal statistics to improve the performance of a data independent beamformer derived from the constraint equations;
- ▶ some similarities and differences between beamforming and MIMO systems have been highlighted;
- ▶ broadband beamforming requires the inclusion of tap delay lines.